

AMC-DTx Series Digital Transmitter Module

Based on Armstrong Monitoring's UTX Series transmitter, the DTx has our standard Modbus register set and is compatible with all AMC Digital Monitor options.

Designed to enhance safety, reliability, serviceability, and user experience, the AMC-DTx is a great solution for applications that don't require the full feature-set of our AMC-UTx transmitters.

The integral sensor module is easily changed, and is eligible for the EZ Cal™ service program, taking the work and risk out of maintaining your gas detection system.

SPECIFICATIONS

Detectable Gases

CO, NO₂, Combination CO/NO₂, O₂, Combustibles.

User Interface

Keypad: 3 Button

Indicators: OLED Display (8 lines x 20 characters)
LEDs for Sensor, Operation, Fault

Outputs: Modbus RTU

Electrical

Supply Voltage: 12-24 VDC/VAC, 70mA @ 24VDC

Wiring: 4 Wire - 2 power + 2 communication.

Power: 16-18 AWG shielded with drain wire

Communication: 18-22 AWG shielded with drain wire

Connection: RS-485.

Mechanical

Enclosure: Polycarbonate Blend

Dimensions: 11.8" L x 10.0" W x 5.5" H (300mm x
254mm x 140mm)

Operating Temperature: -4°F to 102°F / -20°C to 40°C

Application

Coverage Area: Approx. 7500 sq. ft. (50' radius)

Recommended Mounting Height:

CO/NO₂/O₂ 4.5 ft. A.F.F.

Combustibles consult factory



FEATURES

- Patented ADAPTiCal™ algorithm ensures calibrations are optimized for the unique operating conditions of each sensor
- Sensors are temperature compensated throughout operating range for accuracy
- Programmable service reminders
- Available Dual Sensor Configuration
- EMI hardened and protected against over-voltage and polarity reversal
- 2 Year Warranty (sensors excluded)
- CO/NO₂ Sensors certified to UL 2075, File No. E2406971

COMMON VARIANTS

AMC-DTx-M400-91A01-X

Modbus RTU Transmitter, CO, 0-100 ppm, Relay

AMC-DTx-M400-98A01-X

Modbus RTU Transmitter, NO₂, 0-10 ppm, Relay

AMC-DTx-M400-VCA01-X

Modbus RTU Transmitter, Combination CO & NO₂ Sensor, Relay



AMC-DTx Series Build Codes

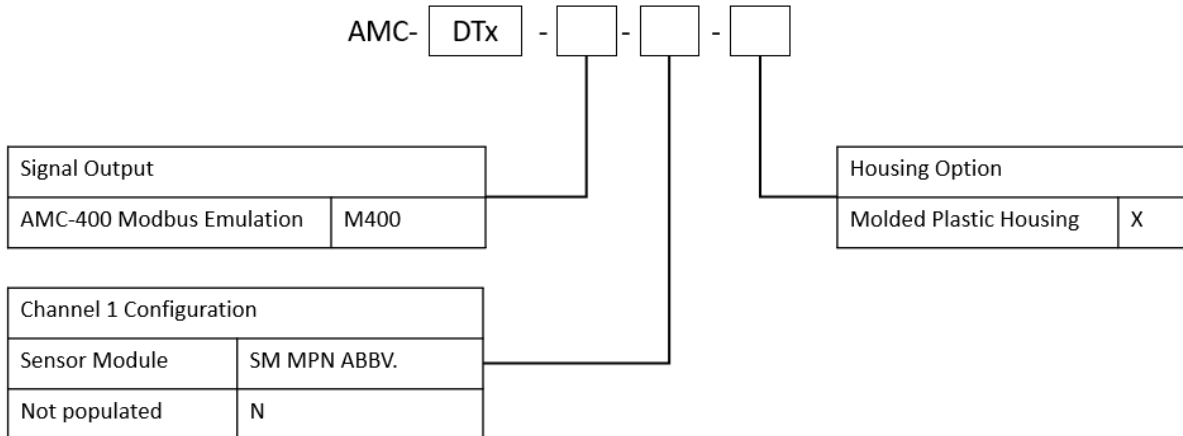

SM MPN Options		
MPN	SM MPN ABBV.	Description
AMC-SM-60A01	60A01	Sensor Module, Methane, 0-100% LEL
AMC-SM-61A01	61A01	Sensor Module, Propane, 0-100% LEL
AMC-SM-62A01	62A01	Sensor Module, Hydrogen, 0-100% LEL
AMC-SM-70A01	70A01	Sensor Module, O2 0-25% Vol
AMC-SM-91A01	91A01	Sensor Module, CO 0-100ppm
AMC-SM-91B01	91B01	Sensor Module, CO 0-300ppm
AMC-SM-98A01	98A01	Sensor Module, NO2 0-10ppm
AMC-SM-VCA01	VCA01	Dual Sensor Module, CO 0-100ppm, NO2 0-10ppm
AMC-SM-VCB01	VCB01	Dual Sensor Module, CO 0-300ppm, NO2 0-10ppm

Warranty: All Armstrong Monitoring equipment is warranted against defects in materials and workmanship for two years from date of delivery, with the exception of sensors. Please contact factory for specific sensor warranty. During the warranty period, we will repair or replace components that prove, in our opinion, to be defective. We are not liable for auxiliary interfaced equipment, nor consequential damage. All warranty returns require a return authorization number. For more information please refer to our Terms & Conditions.

Note: Due to ongoing product development, the manufacturer reserves the right to change specifications without prior notice. The information contained herein is based on data considered accurate. However, no warranty is expressed or implied regarding the accuracy of this data. A variety of factors, not limited to variances in temperature, humidity, pressure, vibrations, EMI/RF may impact on the performance of the equipment. Testing within harsh or unusual environments is recommended. Please contact the factory for assistance with field validation trials.

Published sensor data was obtained using a raw sensor in controlled conditions; actual performance may vary due to site conditions.