



AMC-1BREF Series

Gas Monitor

USER MANUAL



3550440A

Copyright © 2025 AMC

The Armstrong Monitoring Corporation

215 Colonnade Road South, Ottawa, Ontario, Canada K2E 7K3

Tel: (613) 225 9531 • Fax: (613) 225 6965 • Canada & U.S. Toll Free: 1 (800) 465 5777

Email: support@armstrongmonitoring.com • Website: www.armstrongmonitoring.com



Table of Contents

1	General Information	9
1.1	Warranty.....	9
1.2	Liability	9
1.3	Product Return	9
1.4	Contact Information.....	10
1.5	Modifications and Substitutions	10
1.6	Glossary	10
2	Product Information	12
2.1	Product Description.....	12
2.2	Product Specifications	13
2.3	External View	14
2.4	Internal View	15
3	Installation	16
3.1	Monitor Mounting.....	16
3.2	Wiring	18
3.2.1	Power Supply.....	18
3.2.2	Relays.....	18
3.2.3	Analog In (AMC Refrigerant Sensor/Transmitters)	19
3.2.4	Analog Out.....	19
3.2.4.1	<i>VFD Support</i>	19
3.2.5	RAM-4	20
3.2.5.1	<i>Multiple AMC-RAM-4 Wired to a 1B Monitor</i>	23
3.2.6	RAC Display Shunts	23
3.2.7	RAC to Emergency Pull Station (Optional).....	23
3.2.8	Building Automation System (BAS).....	25



4	Operation	29
4.1	Status LEDs	29
4.1.1	Start Up	29
4.1.2	Network Status	29
4.1.3	Faults	30
4.1.4	Alarms	30
4.1.5	Miscellaneous	30
4.2	Menu Overview	31
4.2.1	Normal Operation	31
4.2.2	Failed Sensor	32
4.2.3	Warning/Alarm Indication	32
4.2.4	Fault Indication	34
4.2.5	Detailed Sensor Screen	34
4.2.6	Detailed Status Screen	35
4.2.7	Password Entry	36
4.2.8	Main Service Menu	36
4.2.8.1	<i>Service Menu Timeout</i>	36
4.2.8.2	<i>Service Menu Overview</i>	37
4.2.9	External Sensor Service Menu	38
4.2.9.1	<i>External Sensor Service Menu Overview</i>	38
4.2.9.2	<i>Analog Sub-Menu</i>	38
4.2.9.3	<i>Sensor Sub-Menu</i>	40
4.2.9.4	<i>Gas Label</i>	41
4.2.9.5	<i>Engineering Units</i>	41
4.2.9.6	<i>External Sensor Custom Window Average</i>	42
4.2.9.7	<i>Simulation Of Gas Levels (External Sensors)</i>	42



4.2.9.8	Override.....	43
4.2.9.9	Sim Enable.....	43
4.2.9.10	Sim Gas.....	43
4.2.10	Transmitter Service Menu	44
4.2.10.1	Transmitter Sensors Settings.....	44
4.2.10.2	Sensor Alarm Configuration Sub-Menu	45
4.2.10.3	Transmitter Alarm Settings	48
4.2.10.4	Alarm Sub-Menu	48
4.2.10.5	Transmitter Relay Settings	53
4.2.10.6	Outputs.....	54
4.2.10.7	Buzzer	58
4.2.10.8	Acknowledgement Timer.....	58
4.2.10.9	RTC Date & Time.....	59
5	Maintenance.....	60
5.1	General.....	60
5.2	Verification of Operation	60
5.2.1	LED/Relay Activation Test	60
6	Troubleshooting.....	61
6.1	Symptoms and Corrective Actions.....	61
7	Menu Flow Diagrams	62
7.1	Main Screen / Password Flow	62
7.2	UTx Service Menu.....	63
7.3	Sensor Service Menu.....	65
7.4	Alarm Menu.....	67
7.5	Outputs.....	68
8	Revision History	69



8.1 Document Revision History69



List of Figures

Figure 2-1: External View	14
Figure 2-2: Internal View (1BREF-2 Model Shown).....	15
Figure 3-1: Enclosure Mounting.....	17
Figure 3-2: Relay Contacts.....	18
Figure 3-3: RAC to RAM4 Wiring.....	21
Figure 3-4: Emergency Pull Station.....	24
Figure 3-5: AMC-RAM4 with Displays, BAS and AMC-RAC.....	25
Figure 3-6: Building Automation Wiring to AMC-1BREF	27
Figure 7-1: Main Screen / Password Flow.....	62
Figure 7-2: Service Menu Flow Diagram (a).....	63
Figure 7-3: UTx Service Menu Flow Diagram (b).....	64
Figure 7-4: Sensor Service Menu (a)	65
Figure 7-5: Sensor Service Menu (b)	66
Figure 7-6: Alarm Menu Flow Diagram	67
Figure 7-7: Outputs Menu Flow Diagram.....	68



List of Tables

Table 3-1: Transmitter Wiring	19
Table 3-2: System Configurations with possible VFD support	19
Table 3-3: Wiring to RAM4 External with 2 Displays.....	22
Table 3-4: Wiring to RAM4 Internal with 2 Displays.....	22
Table 3-5: RAC Display Shunt Configuration.....	23
Table 3-6: Wiring 1BREF to Pull Station	24
Table 3-7: AMC-RAC to RAM4 Internal with Display and BAS Channel 1	25
Table 3-8: AMC-RAC to RAM4 External with Display and BAS Channel 2	26
Table 3-9: AMC-RAC to BAS Channel 1	27
Table 3-10: AMC-RAC to BAS Channel 2.....	28
Table 4-1: Status LEDs (Start Up)	29
Table 4-2: Status LEDs (Network Status)	29
Table 4-3: Status LEDs (Faults).....	30
Table 4-4: Status LEDs (Alarms)	30
Table 4-5: Status LEDs (Miscellaneous).....	30
Table 4-6: Service Menu Options.....	37
Table 4-7: External Sensor Menu Options	38
Table 4-8: Analog Sub-Menu Options.....	39
Table 4-9: Sensor Sub-Menu Options	40
Table 4-10: Engineering Unit Options.....	42
Table 4-11: External Override Sub-Menu Options.....	42
Table 4-12: Transmitter Service Menu.....	44
Table 4-13: Sensor Module Configuration Menu.....	45
Table 4-14: Sensor Alarm Configuration	45
Table 4-15: Calibration Frequency Configuration.....	47



Table 4-16: Transmitter Alarm Settings48

Table 4-17: Transmitter Alarm Sub-Menu Settings48

Table 4-18: Alarm Input Options.....50

Table 4-19: Alarm Setpoint Options51

Table 4-20: Outputs Sub-Menu54

Table 4-21: Buzzer Menu.....58

Table 6-1: Troubleshooting61

Table 8-1: Document Revision History69



1 General Information

1.1 Warranty

This product is warranted against defects in material and workmanship for a period of two years from date of delivery. Maintenance items are not warranted. During the warranty period, The Armstrong Monitoring Corporation will repair or replace components that prove to be defective in the opinion of AMC. Any equipment deemed to be defective by the user should be returned to The Armstrong Monitoring Corporation for evaluation (see product return below). Site visits by Armstrong personnel, to evaluate/repair equipment, are not covered by this warranty unless covered under the site contract. AMC is not liable for auxiliary interfaced equipment, nor for consequential damage. This warranty shall not apply to any product which has been modified in any way, which has been repaired by any other party other than a qualified technician or authorized AMC representative, or when failure is due to misuse or conditions of use.

Note: Extended Warranty and mail in calibration programs are available (please call 1-800-465-5777) or see our contacts page at www.armstrongmonitoring.com

1.2 Liability

All AMC products must be installed and maintained according to instructions. Only qualified personnel should install and maintain the equipment. This product must not be placed in areas with combustible gases reaching 100% LEL (environments prone to explosions).

AMC shall have no liability arising from auxiliary interfaced equipment, for consequential damage, or the installation and operation of this equipment. AMC shall have no liability for labor or freight costs, or any other costs or charges in excess of the amount of the invoice for the products.

THIS WARRANTY IS IN LIEU OF ALL OTHER WARRANTIES, EXPRESSED OR IMPLIED AND SPECIFICALLY THE WARRANTIES OF MERCHANTABILITY AND FITNESS FOR A PARTICULAR PURPOSE. THERE ARE NO WARRANTIES THAT EXTEND BEYOND THE DESCRIPTION ON THE FACE THEREOF.

1.3 Product Return

All products returned for warranty or service should be shipped by prepaid freight and will be accepted only with RMA or repair number issued by AMC.



1.4 Contact Information

For information, please call 1-800-465-5777, visit www.armstrongmonitoring.com or email directly support@armstrongmonitoring.com.

1.5 Modifications and Substitutions

Due to an ongoing development program, AMC reserves the right to substitute components and change specifications at any time without incurring any obligations.

1.6 Glossary

Act Delay	The delay in seconds between the gas concentration reaching an alarm setpoint, and the corresponding alarm level activating.
Alarm	Alarm is an audible, visual, or physical presentation designed to warn the instrument user that a specific level of a dangerous gas/vapor concentration has been reached or exceeded.
Calibration	Calibration is the procedure used to adjust the instrument for proper response.
Calibration Gas	Calibration Gas is a gas of known concentration used in adjusting and testing gas detection equipment to ensure proper function and accurate readings.
Gas Concentration	Gas Concentration can be measured in: <ul style="list-style-type: none">• ppm• %LEL• %LFL• % Volume
Hysteresis	A user-set difference from an alarm's setpoint prevents frequent alarm activation. Hysteresis solely impacts alarm deactivation, not its activation tied to the setpoint.
LEL	Lower Explosive Limit is the lowest concentration (percentage) of a gas or a vapor in air capable of combusting in the presence of an ignition source (arc, flame, heat).
Min Run	The minimum time in seconds that an alarm state will remain active, even if the gas concentration has returned above/below the setpoint +/- hysteresis (based on a decreasing or increasing alarm type).
ppm	Parts Per Million (1% volume = 10,000ppm)
Percent by Volume	Concentration of gas in a mixture expressed as a percentage of total volume.
Span	The difference between the highest concentration and lowest concentration.
T90	Response Time in seconds to achieve 90% gas concentration reading.



T99	Response Time in seconds to achieve 99% gas concentration reading.
VFD	Variable Frequency Drive
Zero Buffering	Zero buffering is a function of the monitor which forces the gas concentration reading to zero when sensor is exposed to low concentration of a gas. The zero buffer is indicated in the sensor specification.
Zero Gas	Zero gas is gas in which the target gas is not present. The presence of oxygen is required. Clean air is an excellent source for zero calibration. A known gas concentration can be entered during zero calibration.

2 Product Information

2.1 Product Description



The AMC-1BREF Gas Monitors are designed to work with the AMC Refrigerant Sensor/Transmitters and the RAM4 Refrigerant Alarm Modules. The Monitor is available in 1 channel (AMC-1BREF-1) or two channel variants (AMC-1BREF-2). Each channel supports one 4-20mA Refrigerant Transmitter

The Monitor provides a digital representation of the gas concentration; this information is displayed locally via OLED display.

In addition, each Monitor features alarm / system status indicators, audible feedback, 3 relays (Warning, Alarm and Vent), 2 analog outputs to support optional displays on the RAM4 and colour-coded connection terminal blocks, as listed and described herein.

NOTE: The AMC-1BREF is a variant of our UTx platform. As such many of the menu items directly reference the parent product.



2.2 Product Specifications

System	
System Warranty Period	2 Years
Power Supply Requirement	120 VAC, 60 Hz, 53 VA
Relays	3x DPDT, 250 VAC, 10 A
Operating Temperature	-4 to 104F (-20 to 40C)
Operating Pressure	0.9 to 1.1 atm
Humidity Range	15 to 90% RH, non-condensing
Terminal Block Torque	7 inch-pounds (0.8 N-m)
Analog Out	
Topology	Sourcing
Voltage Range	0-10 V
Current Range	0-20 mA. Default configuration has 4-20mA output used to drive displays on RAM4 Modules
Corner Frequency	300 KHz
Analog In	
Current Range	4-20mA
Real Time Clock (RTC)	
Battery Size	CR1025, Field Replaceable.
Expected Battery Life	> 2 Years

2.3 External View

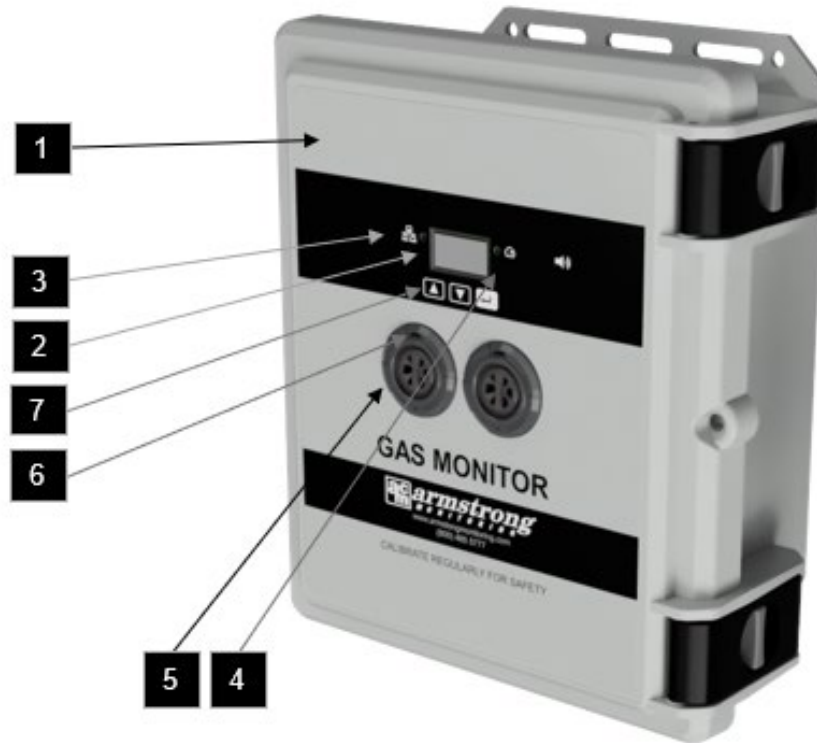

Figure 2-1: External View

1	Enclosure	Enclosure and Lid Assembly, UV Stabilized Polycarbonate, 11.750" L x 9.980" W x 5.460" H (300 x 250 x 140mm)
2	Digital Display	Display Gas Concentration & Status Information
3	Network Status LED	Not applicable to 1BREF Series
4	Alarm Status LED	The Sensor Status LED will show the same error code that is being communicated by the Sensor Module(s) or display the highest priority error (if multiple errors codes are being communicated to it by the Sensor Module(s))
5	Sensor Module Opening	Not applicable to 1BREF series
6	Sensor Module LED	Not applicable to 1BREF series
7	Menu Buttons	Momentary Pushbuttons for user interface.

2.4 Internal View

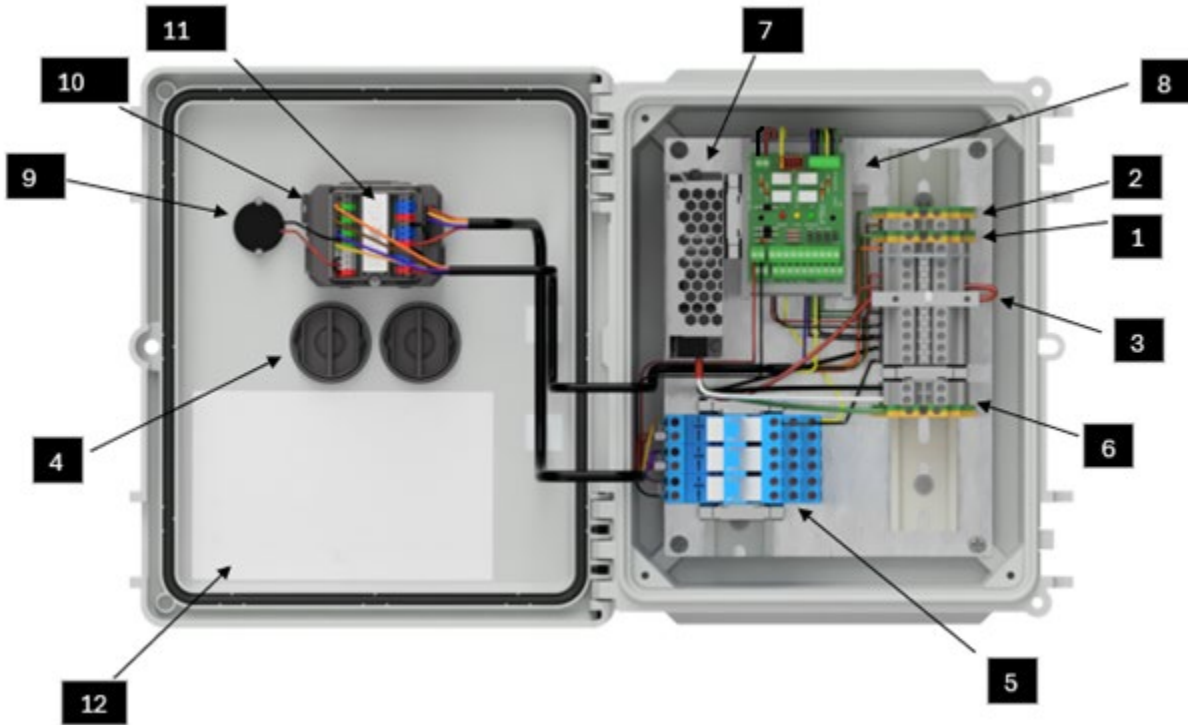

Figure 2-2: Internal View (1BREF-2 Model Shown)

1	Analog Input 1	Terminal Blocks for Channel 1 Input
2	Analog Input 2	Terminal Blocks for Channel 2 Input (AMC-1BREF-2 Only)
3	2A Fuse	Device Level Input Protection
4	Sensor Module	Not applicable to 1BREF series
5	External Relays	Connection for Alarm/Warning/Vent Systems
6	Voltage IN	Terminal Block for Main Power In
7	Power Supply	Regulates power for the device.
8	AMC-RAC	Provides connections for RAM4 Modules
9	Buzzer	Provides audible indication upon alarm state.
10	UTx Main Module	Information processing and communications hub.
11	Bus Power Module	Provides power and communications interface to the UTx.
12	Internal Wiring Label	Provides details of connections to the 1BREF components



3 Installation

The installation of the AMC-1BREF Gas Monitor is very important as the operational quality is a direct result of the quality of the installation. The following sections provide guidelines for installation; location and mounting, wiring, and cable selection.

3.1 Monitor Mounting

Care should be taken to securely fasten the monitor unit on a solid, non-vibrating surface or structure so that the Monitor is located at approximately 4ft to 6 ft (1.2m to 1.8m) above floor level or per local regulations. Mount the monitor where the unit can be observed periodically. See the below **Enclosure Mounting** figure for mounting hole locations.

CAUTION: All cable entry **MUST BE** through the **BOTTOM** of the monitor enclosure only. Other entry locations will allow foreign materials to enter the enclosure, causing possible damage to the internal components.

Warning:

Conduit entry from the top or back of the housing is Not Recommended. Any water damage related to conduit entry from the top or back will not be covered under warranty.

Qualified personnel should perform the installation according to applicable electrical codes, regulations and safety standards. Ensure correct cabling practices are implemented.

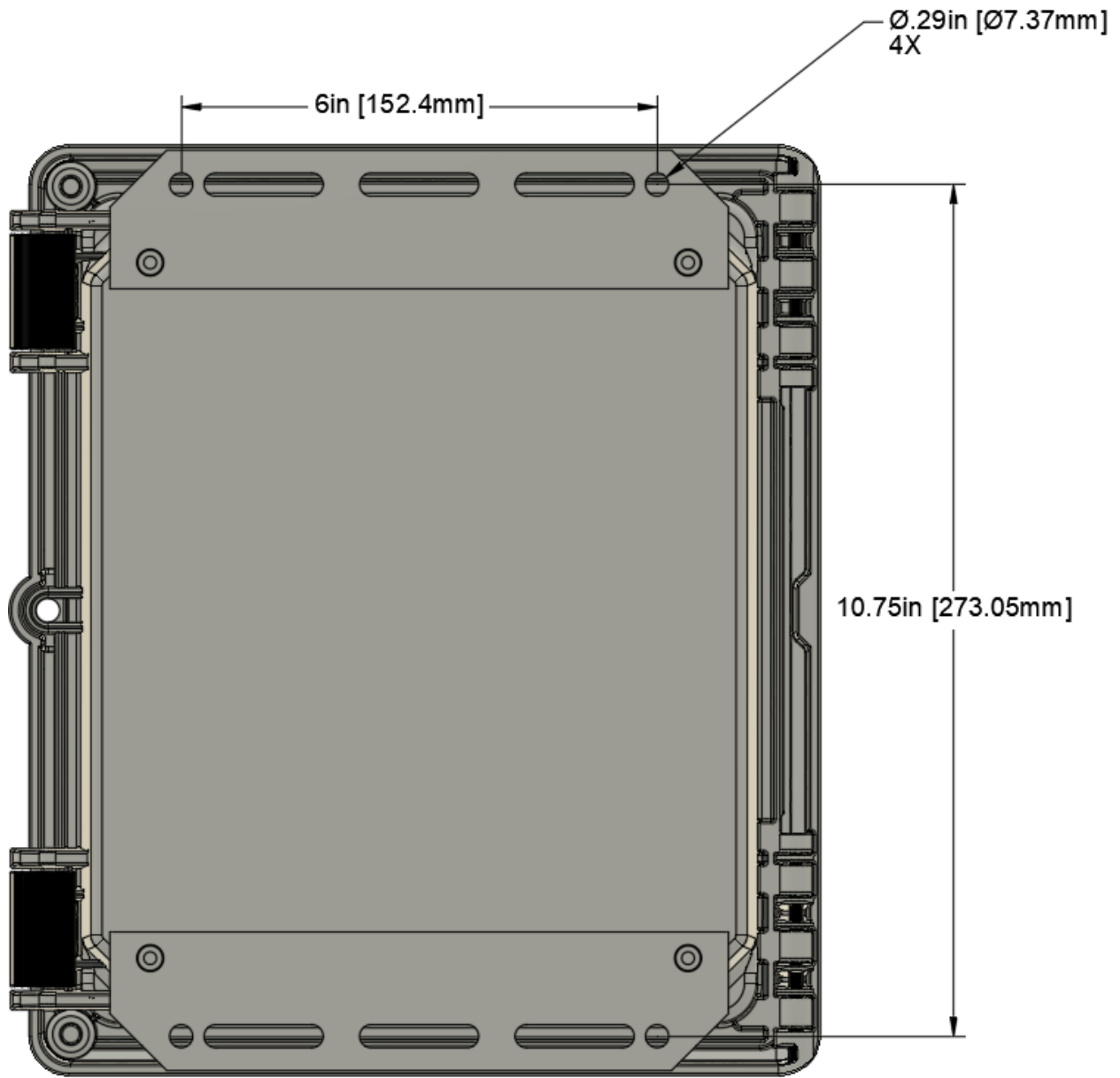

Figure 3-1: Enclosure Mounting



3.2.3 Analog In (AMC Refrigerant Sensor/Transmitters)

The analog input terminal blocks are used for connecting Sensor Modules. The wiring for channel 1 and 2 is conveyed in the following table.

Table 3-1: Transmitter Wiring

Gas Monitor	Refrigerant Sensor Module
Chassis Ground	Connect to the cable shield
Negative -	Negative -
Signal S	AO1 (for UTx-REF Sensor 1) AO2 (if UTx-REF Sensor 2 is populated)
Positive +	Positive +

NOTE: If connecting to both AO1 and AO2 on a UTx-REF Transmitter that has dual sensors both Input Channels on the 1BREF will be used, and no further Transmitters can be connected.

For further detailed wiring instructions see the corresponding sensor module manual.

3.2.4 Analog Out

When used with RAM4 Modules with displays the Analog Outputs are configured for 4-20mA and fed through the REF-RAC Module to provide input to the RAM4 displays. Depending upon the system configuration there may be Analog Outputs available for use with VFD devices per the following section.

3.2.4.1 VFD Support

The table below shows system configurations that can support a VFD interface. If a VFD interface is required contact AMC for details on how to configure the system.

Table 3-2: System Configurations with possible VFD support

1BREF Version	Number of Transmitters	Number of RAM4 Displays	VFD Support Possible	RAC Configuration Notes
1BREF-1	1	0	yes	VFD output on REF1 +/-
1BREF-1	1	1	no	n/a
1BREF-2	1	0	yes	VFD output on REF2 +/-
1BREF-2	1	1	yes	VFD output on REF2 +/-
1BREF-2	1	2	no	Configuration exists with UTx-REF with two Sensor Modules (for example ppm and %LFL)
1BREF-2	2	0	yes	VFD output on REF2 +/-
1BREF-2	2	1	yes	VFD output on REF2 +/-



1BREF-2	2	2	no	n/a
---------	---	---	----	-----

NOTE: VFD connections would be on the RAC Circuit Board (Item 8 in the Internal View Diagram in Section 2.4)

3.2.5 RAM-4

The Remote Alarm Controller provides communication between the AMC-1BREF monitor and AMC-RAM-4 Refrigerant Alarm Modules. Its functions include controlling the ventilation relay manually by remote fan switches on the AMC-RAM-4 or automatically if a refrigerant leak is detected.

The AMC-RAC is factory wired to the AMC-1BREF monitor through the Analog Outputs and the Relays; the signals are relayed to the AMC-RAC which then sends the signal out to the attached peripherals. Communication from the AMC-RAM-4 is also relayed through the AMC-RAC to activate the ventilation relay.

The AMC-RAM-4 units are connected to the AMC-1BREF monitor through the AMC-RAC as shown below. Please utilize Tables and Figure drawings to complete wiring.

IMPORTANT NOTE:

Internal RAM-4 units are installed inside Chiller rooms while External RAM-4 units are installed outside Chiller rooms. External units do not have a stop button while the Internal units have a stop button.

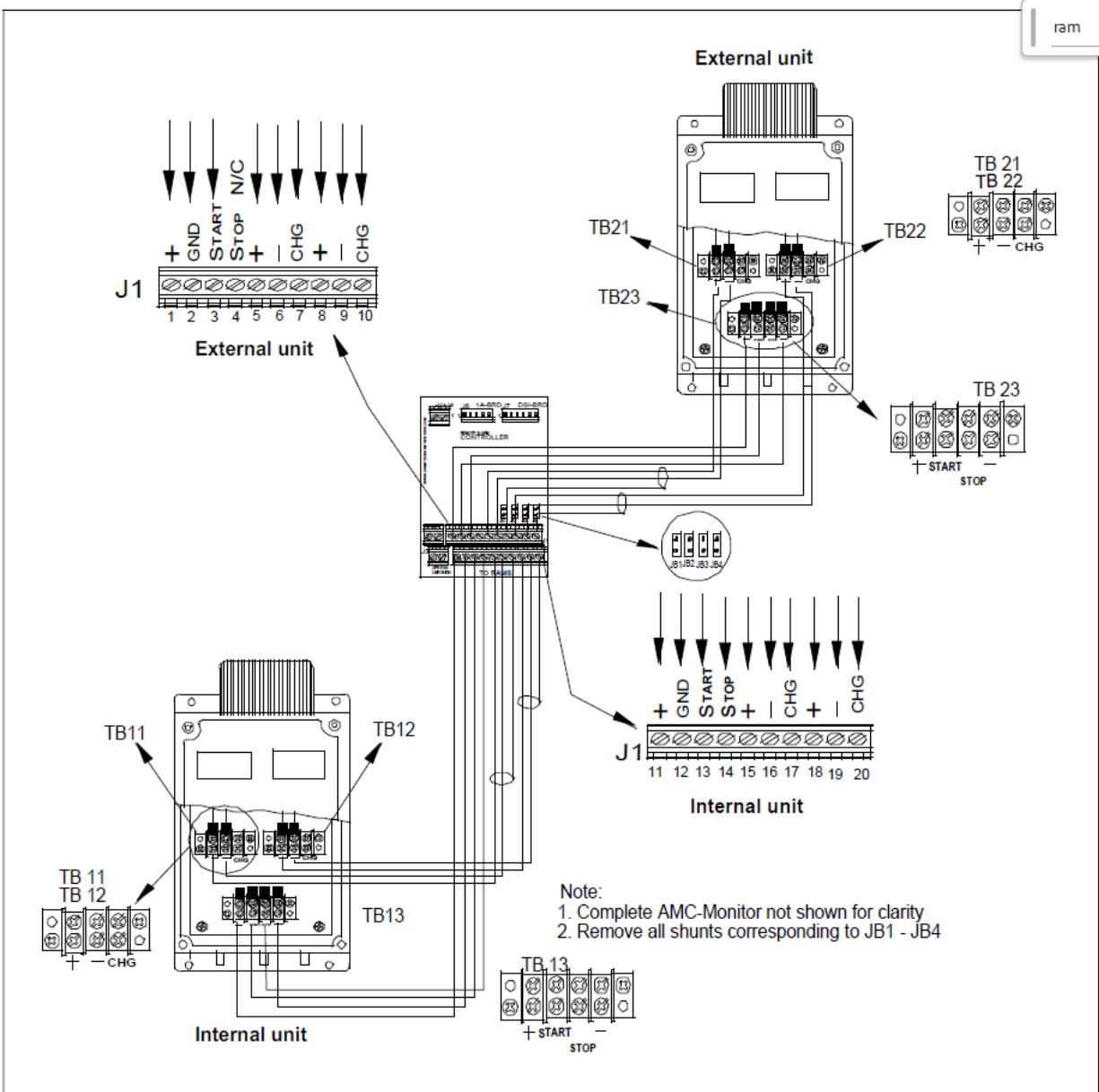

Figure 3-3: RAC to RAM4 Wiring

NOTE: The + and – signals on J1 pins 5,6,8,9,15,16,18,19 carry 4-20 loop current while pin 1 + is required for RAM4 power. Ensure tables and figure drawings are followed when wiring units due to differences in signal functions.



Table 3-3: Wiring to RAM4 External with 2 Displays

RAM-4	Function	AMC-1BREF Monitor (RAC)
TB23		J1 Terminal Block Position
(+)	RAM-4 Alarm	1
START	Activate Vent Relay	3
STOP	Deactivate Vent Relay	N/C
(-)	Ground	2
TB21		J1 Terminal Block Position
(+)	CH1 Current Loop Positive 1	5
(-)	CH1 Current Loop Negative 1	6
CHG	Current Loop Chassis Ground	7
TB22		J1 Terminal Block Position
(+)	CH2 Current Loop Positive 1	8
(-)	CH2 Current Loop Negative 1	9
CHG	Current Loop Chassis Ground	10

Table 3-4: Wiring to RAM4 Internal with 2 Displays

RAM-4	Function	AMC-1BREF Monitor (RAC)
TB13		J1 Terminal Block Position
(+)	RAM-4 Alarm	11
START	Activate Vent Relay	13
STOP	Deactivate Vent Relay	14
(-)	Ground	12
TB11		J1 Terminal Block Position
(+)	CH1 Current Loop Positive 1	15
(-)	CH1 Current Loop Negative 1	16
CHG	Current Loop Chassis Ground	17
TB12		J1 Terminal Block Position
(+)	CH2 Current Loop Positive 1	18
(-)	CH2 Current Loop Negative 1	19
CHG	Current Loop Chassis Ground	20



3.2.5.1 Multiple AMC-RAM-4 Wired to a 1B Monitor

When more than two AMC-RAM-4 modules are required, the modules can be connected in parallel BUT the optional displays have to be connected in series.

Caution: Ensure that the power supply at the monitor is large enough to power all devices or use the configuration that has no more than 2 displays per channel.

Refer to the RAM-4 User Manual for details on this wiring option.

3.2.6 RAC Display Shunts

The RAC J1 Pins 1-10 always connect to external units while the RAC J1 Pins 11-20 always connect to internal units. The shunts must be installed correctly to ensure the display current loops exist for different configurations.

The balance of RAM-4 functions do not depend on these shunts.

Table 3-5: RAC Display Shunt Configuration

JB1-4 Install	RAM4 Configuration
No shunts installed	1 External 2 Display and 1 Internal 2 Display (both Ch1/2 used)
No shunts installed	1 External 1 Display and 1 Internal 1 Display (only CH1 used)
JB2, JB4 installed	2 External 2 Display and 2 Internal No Display (both Ch1/2 used)
JB2 installed	2 External 1 Display and 2 Internal No Display (only CH1 used)
JB1, JB3 installed	2 Internal 2 Display and 2 External No Display (both Ch1/2 used)
JB1 installed	2 Internal 1 Display and 2 External No Display (only CH1 used)

3.2.7 RAC to Emergency Pull Station (Optional)

The Emergency Pull Station (AMC-EPS) is located immediately outside the mechanical room door and is intended to shut down any interlocked equipment in case of an emergency. The Pull Station is wired to the system through the AMC-RAC as shown in Figure 4 6. Once the Pull Station lever is pulled, it activates the alarm relay until the switch is reset.

Recommended wire size is 18-22 AWG and distance between AMC-RAC and pull station should not be more than 500 feet.

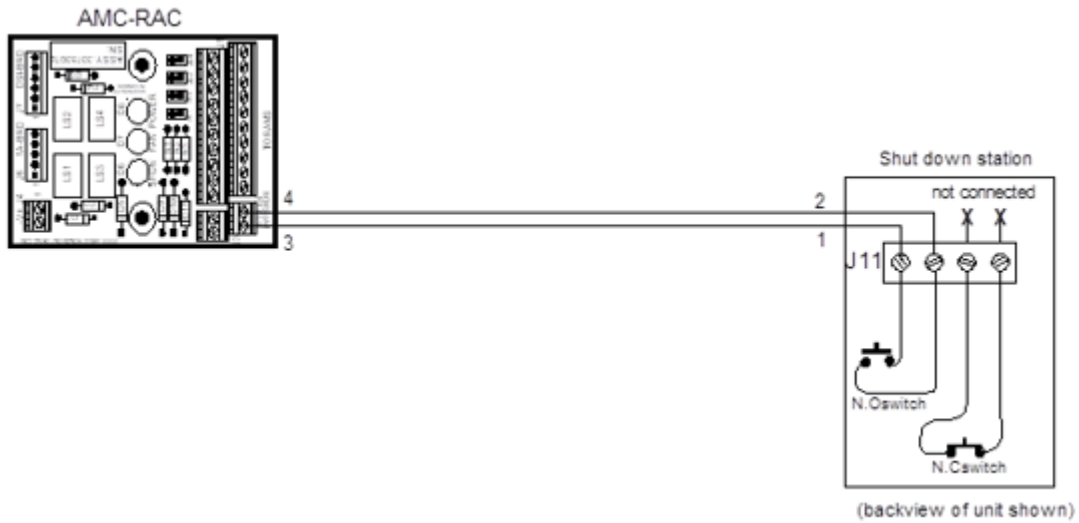

Figure 3-4: Emergency Pull Station

NOTE:

1. Other internal components of the monitor removed for clarity.
2. Maximum wire size used to interconnect units is 18 AWG.

Table 3-6: Wiring 1BREF to Pull Station

RAC J3	Function	Shut Down Station J11
3	Positive	1
4	GND	2

3.2.8 Building Automation System (BAS)

The building automation system (BAS) can be wired to the Gas Monitor through the AMC-RAC. The BAS can also be wired in series with AMC-RAM-4 module with displays through the AMC-RAC.

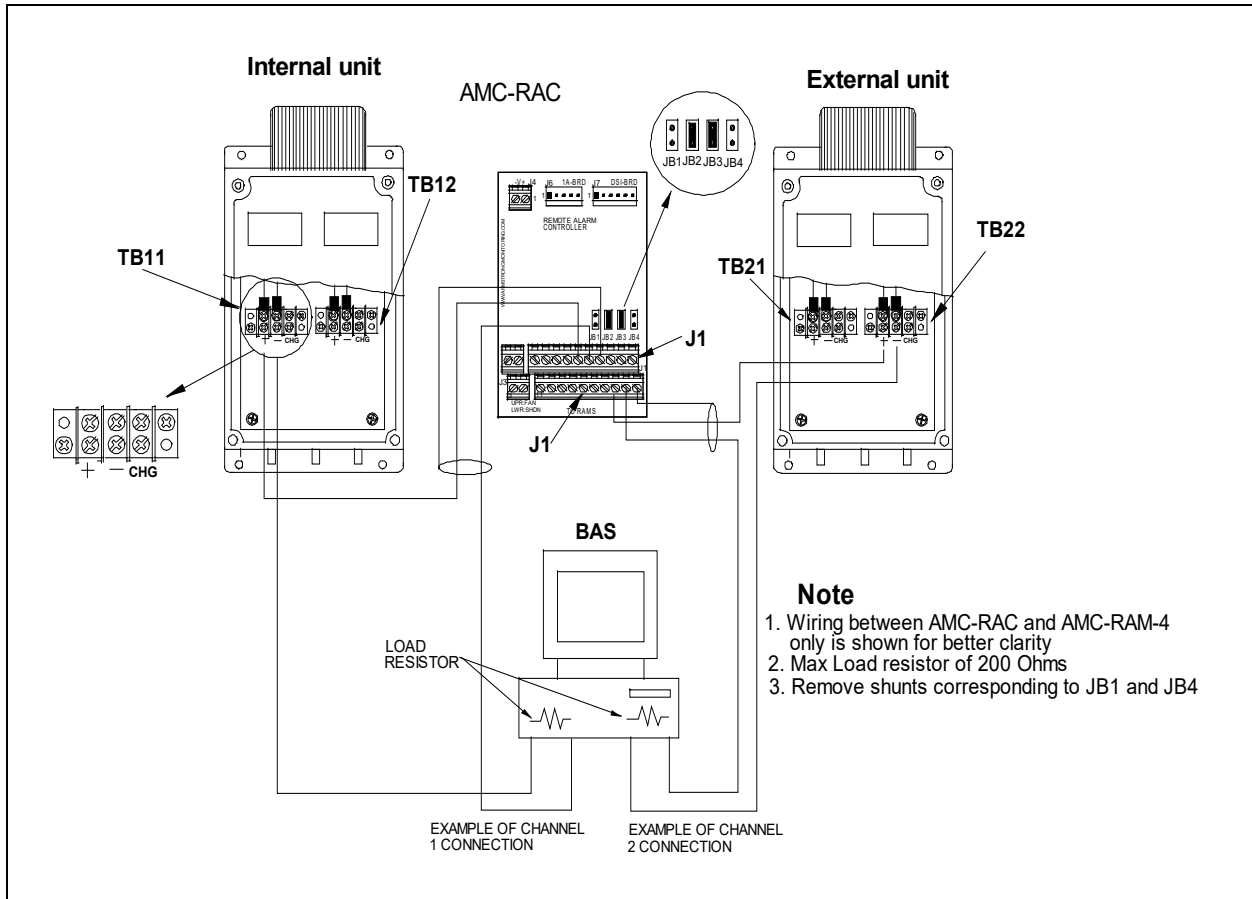

Figure 3-5: AMC-RAM4 with Displays, BAS and AMC-RAC

Table 3-7: AMC-RAC to RAM4 Internal with Display and BAS Channel 1

AMC-RAC	Function	RAM4	BAS CH1
J1 Terminal Block pos.5 (+)	CH1. Current Loop Positive 1	TB 11(internal) +	
N/A		TB 11(Internal) -	(+)
J1 Terminal Block pos.6 (-)	CH1. Current Loop Negative 1	N/A	(-)
J1 Terminal Block pos.7 (CHG)	Current Loop Chassis Ground		



Table 3-8: AMC-RAC to RAM4 External with Display and BAS Channel 2

AMC-RAC	Function	RAM4	BAS CH2
J1 Terminal Block pos.18 (+)	CH2. Current Loop Positive 1	TB 22(external) +	
N/A		TB 22(external) -	(+)
J1 Terminal Block pos.19 (-)	CH2. Current Loop Negative 1	N/A	(-)
J1 Terminal Block pos.20 (CHG)	Current Loop Chassis Ground		

NOTE: CABLE SHIELD MUST BE GROUNDED AT ONE END ONLY, EITHER AT GAS MONITOR OR BAS BUT NOT BOTH.

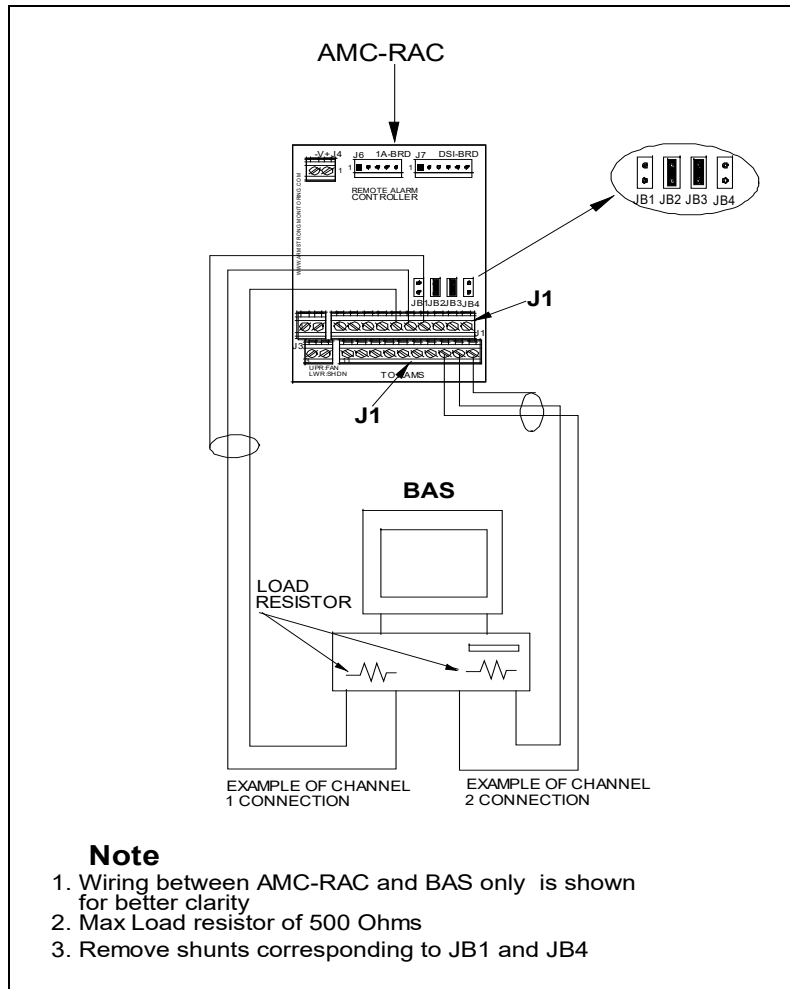

Figure 3-6: Building Automation Wiring to AMC-1BREF

Table 3-9: AMC-RAC to BAS Channel 1

AMC-RAC	Function	BAS CH1
J1 Terminal Block pos.5 (+)	CH1. Current Loop Positive 1	(+)
J1 Terminal Block pos.6 (-)	CH1. Current Loop Negative 1	(-)
J1 Terminal Block pos.7 (CHG)	Current Loop Chassis Ground	



Table 3-10: AMC-RAC to BAS Channel 2

AMC-RAC	Function	BAS CH2
J1 Terminal Block pos.18 (+)	CH2. Current Loop Positive 1	(+)
J1 Terminal Block pos.19 (-)	CH2. Current Loop Negative 1	(-)
J1 Terminal Block pos.20 (CHG)	Current Loop Chassis Ground	

NOTE:

- | |
|--|
| <ol style="list-style-type: none">1. Wire length for the following setups is the same; Gas Monitor 1B x2 Display with BAS 200 Ohms resistance and Gas Monitor 1B x 1 Display with BAS 450 Ohms resistance.2. Recommended maximum load resistance BAS is 200 Ohms per channel; for setup AMC-1BREF monitor, RAM-4 with 2 Displays per channel. |
|--|



4 Operation

This section describes how the functionalities of the AMC-1BREF Monitor are operated and performed. Please consult the operation and initial configuration chapters below before attempting to use or calibrate the Gas Monitor.

4.1 Status LEDs

Refer to the **External View** section for LED location and descriptions. During operation the LEDs will display the following configurations:

4.1.1 Start Up

Table 4-1: Status LEDs (Start Up)

LED Status	Network LED	Alarm Status LED	Display Screen Message
Initialization and discovery of Sensor Modules (after UTx is powered up).	OFF	Solid WHITE	AMC Splash Screen
Sensor Warm-up	Flashing GREEN (1 sec Cycle)	Solid WHITE	Main Info Screen (or blank) No Sensor Gas Readings Shown

4.1.2 Network Status

Table 4-2: Status LEDs (Network Status)

LED Status	Network LED	Alarm Status LED	Display Screen Message
Network status does not apply to 1B monitors.	Flashing GREEN (1 sec Cycle)		Not Indicated on Display Screen



4.1.3 Faults

Table 4-3: Status LEDs (Faults)

LED Status	Network LED	Alarm Status LED	Display Screen Message
Fault 1			
External Sensor Input Below Fault Value	Flashing GREEN (1 sec cycle)	Solid RED	Gas Bar Indicates “FAULT” For Affected Sensors

4.1.4 Alarms

Table 4-4: Status LEDs (Alarms)

LED Status	Network LED	Alarm Status LED	Display Screen Message
Threshold 1 Reached	Flashing GREEN (1 sec Cycle)	Solid YELLOW	Gas Bar Indicates “WARN” For Affected Sensors
Threshold 2 Reached	Flashing GREEN (1 sec Cycle)	Solid RED	Gas Bar Indicates “ALARM” For Affected Sensors

4.1.5 Miscellaneous

Table 4-5: Status LEDs (Miscellaneous)

LED Status	Network LED	Alarm Status LED	Display Screen Message
Low RTC Battery	Flashing GREEN (1 sec cycle)	Flashing MAGENTA (1 sec cycle)	Not Indicated on Display Screen
Real-Time Clock (RTC) Disabled or Uninitialized	Flashing GREEN (1 sec cycle)	Solid MAGENTA	Not Indicated on Display Screen



4.2 Menu Overview

Note that a **Menu Flow Chart** is available further in this manual. The menu images and menu flow diagrams in this manual represent gas types with labels such as “GAS1”, “GAS2”, etc. These are mapped to specific gases based on the customer order.

4.2.1 Normal Operation

Upon startup, a brief splash screen is shown on the display which includes the Armstrong Monitoring Corp’s logo and the current version of the UTx firmware. After a couple of seconds, the display will update to show the main info screen (see below). NOTE: The bar graphs indicating gas concentration are not visible initially while the sensor modules are warming up. The warm-up period will be shown in the details section for the selected sensor until the warm-up period expires.

NOTE: Factory configurations define a warm-up default value that prevents false alarms while sensors are warming up. This value may be viewed during warm-up through the detailed sensor screen section.

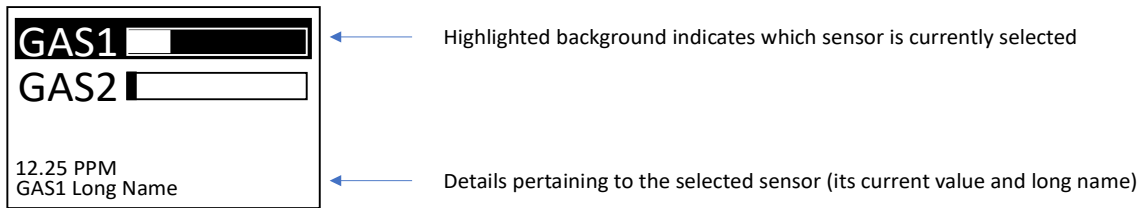

As shown above, two sensors are currently attached to the transmitter. Only one sensor can be selected at a time for the purpose of inspecting its details. Use the **UP** and **DOWN** buttons to navigate between each sensor. The following diagram illustrates the main info screen after pressing the **DOWN** button from the previous display. Notice how the details are updated to reflect the newly selected sensor.

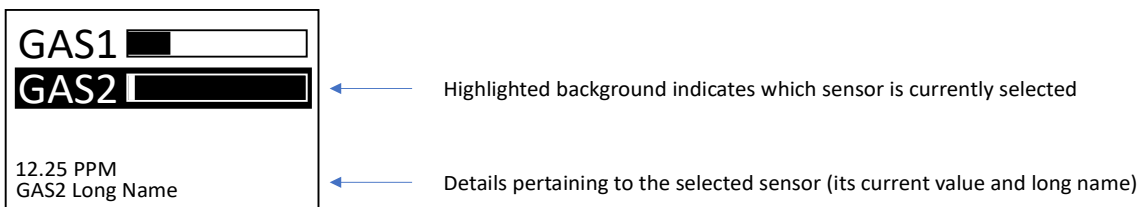

After a programmed timeout period without any button presses, the display will go blank (screen saver mode). To re-enable the display, simply press the **ENTER** button.

4.2.2 Failed Sensor

In the event of a failed sensor, the bar graph is replaced with a large FAIL indication and the detailed description is updated accordingly. If the sensor fails while the display is OFF, the display will immediately turn ON and the failed sensor will be selected by default. In addition, the FAIL indication will toggle between normal and inverse ‘white space’ mode at a rate of once per second as shown below.

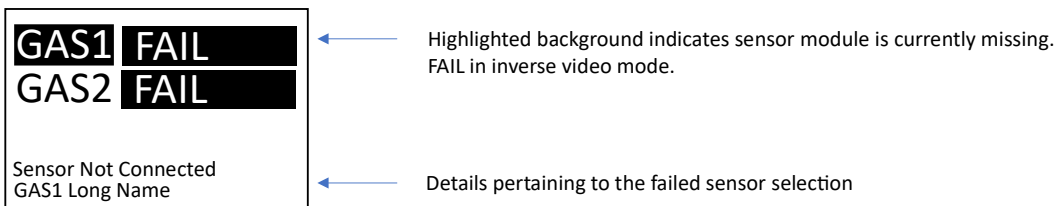
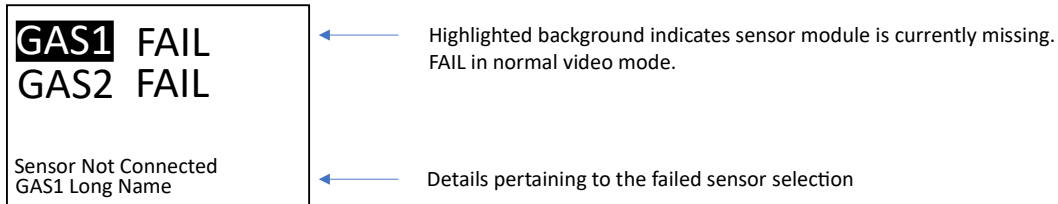

If the failure condition is resolved, the main display for the failed sensor will resume normal operation by indicating the sensor reading via bar graph.

4.2.3 Warning/Alarm Indication

When a warning or an alarm occurs, the bar graph is replaced with a large WARN indication for warnings or a large ALARM for alarms. If the sensor enters a warning or alarm state while the display is OFF, the display will immediately turn ON and the sensor responsible for the warning/alarm will be selected by default. The WARN/ALARM indication will toggle between normal and inverse ‘white space’ mode at a rate of once per second as shown below.

The user has the option to silence the buzzer while the warning/alarm condition is still active. To silence the alarm, the channel responsible for the warning/alarm needs to be selected and the user needs to press the **ENTER** button. Once silenced, the contextual help (small text) will provide an indication of how long the audio buzzer will remain silenced. Once this period expires, the previous ‘Press ENTER to ACK’ message will return, and the buzzer will resume operation.

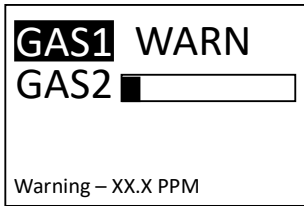

Highlighted background indicates which sensor is currently in a warning state. WARN in normal video mode.

Details pertaining to the sensor

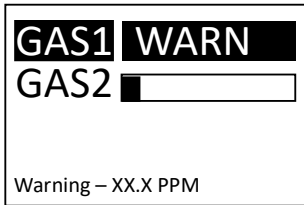

Highlighted background indicates which sensor is currently in a warning state. WARN in inverse video mode.

Details pertaining to the sensor

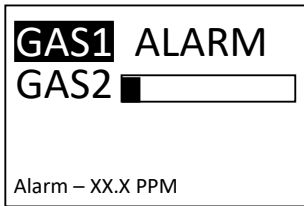

Highlighted background indicates which sensor is currently in alarm. ALARM in normal video mode.

Details pertaining to the selected sensor which is currently in alarm. The current sensor reading is shown.

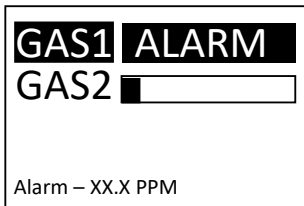

Highlighted background indicates which sensor is currently in alarm. ALARM in inverse video mode.

Details pertaining to the selected sensor which is currently in alarm. The current sensor reading is shown.

For units configured at factory to use latched alarms, when the alarm condition is cleared the display will indicate that the relays are latched until cleared by the user by pressing the **ENTER** button to release the latching condition.

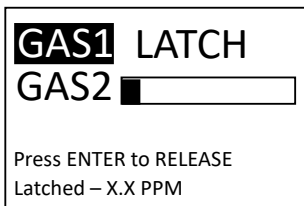

Highlighted background indicates which sensor is currently selected with latched relays. LATCH in normal video mode.

Details pertaining to the selected sensor which currently has its relays in Latched mode. The current sensor reading is shown with an instruction to press the **ENTER** button to release the relays from their active state.

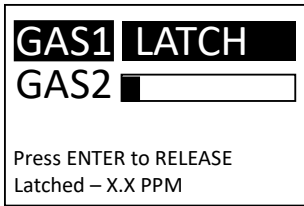

Highlighted background indicates which sensor is currently selected with latched relays. LATCH in inverse video mode.

Details pertaining to the selected sensor which currently has its relays in Latched mode. The current sensor reading is shown with an instruction to press the **ENTER** button to release the relays from their active state.

4.2.4 Fault Indication

The following two menu images show a fault condition in normal and inverse video modes.

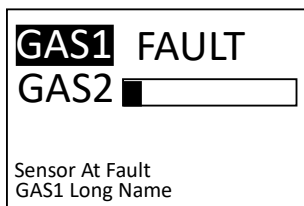

Highlighted background indicates which sensor is currently at fault. FAULT in normal video mode.

Details pertaining to the sensor at fault

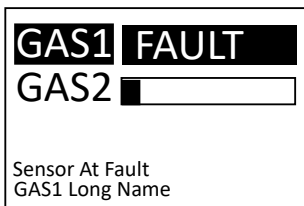

Highlighted background indicates which sensor is currently at fault. FAULT in inverse video mode.

Details pertaining to the sensor at fault

4.2.5 Detailed Sensor Screen

To access the detailed information for each sensor, press and hold the **UP** button until the following screen appears.

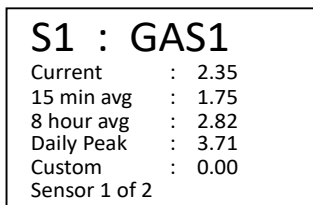

- ← Label indicates which sensor is currently selected
- ← Current instantaneous value for the selected sensor
- ← 15 min average value for the selected sensor
- ← 8 hour average value for the selected sensor
- ← Daily peak value for the selected sensor
- ← Custom filter value for the selected sensor (if specified, 0 otherwise)
- ← Paging info updated as different sensors are selected using **UP/DOWN** buttons

The detailed sensor screen provides several values for each sensor. Use the **UP** and **DOWN** buttons to page through all the attached sensors. This detailed screen will timeout after 30 seconds if no button is pressed thereby returning the user back to the main info screen. Alternatively, the user can exit the detailed sensor screen on demand by pressing the **ENTER** button to return back to the main info screen.



4.2.6 Detailed Status Screen

To access the detailed status for each sensor, press and hold the DOWN button until the following screen appears.

S1 : GAS1	←	Label indicates which sensor is currently selected
Status : Normal	←	Current operational status for the selected sensor
Last Cal : 76 days	←	Number of days since last calibration for the selected sensor
Next Cal : 104 days	←	Number of days until next calibration for the selected sensor
Lifetime : 2126 days	←	Remaining sensor life for the selected sensor
S/N : 1234	←	Serial number for the selected sensor
Sensor 1 of 2	←	Paging info updated as different sensors are selected using UP/DOWN buttons

The detailed status screen provides the complete status for each sensor. Use the UP and DOWN buttons to page through all the attached sensors. This detailed screen will timeout after 30 seconds if no button is pressed thereby returning the user back to the main info screen. Alternatively, the user can exit the detailed status screen on demand by pressing the ENTER button to return to the main info screen.

NOTE: All information dependent on the real-time clock (RTC) such as 'Last Cal' or 'Next Cal' may be incorrect if the RTC is currently disabled or uninitialized (as indicated by a solid magenta on the Alarm Status LED).

Continuing to press **DOWN** after the sensor pages show the firmware version of up to all four modules that are available on the UTx platform. This list also displays the date and time for convenience.

FIRMWARE	←	'Firmware' serves as a label only
TM : v5.14	←	Transmitter (UTx) firmware version
DM : v5.14	←	Display module firmware version
SM1 : v5.14	←	First sensor module version, if applicable
SM2 : v5.13	←	Second sensor module version, if applicable
YYYY-MM-DD HH:MM:SS	←	Date and time information

4.2.7 Password Entry

To access the service menu system, the user needs to press and hold the **ENTER** button until the following password entry screen is displayed.

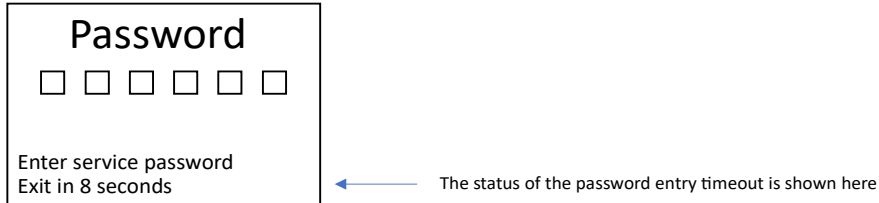

Enter the password using a combination of the **UP**, **DOWN** and **ENTER** buttons. The password is factory set to **UP - DOWN - UP - DOWN - ENTER - ENTER**. As the password is being entered, the display updates with each button press. The diagram below illustrates the state of the password entry after 3 button presses. The password entry screen will timeout after 10 seconds if no button is pressed thereby returning the user back to the main info screen.

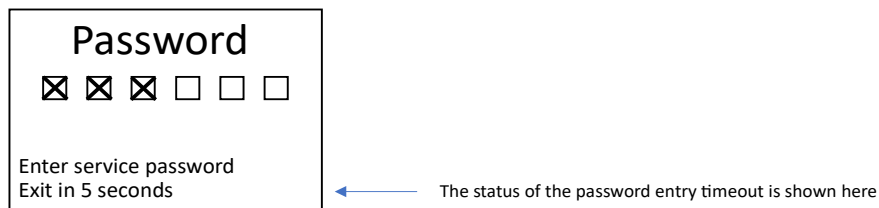

4.2.8 Main Service Menu

4.2.8.1 Service Menu Timeout

The service menus remain unlocked for a programmed timeout period (set to 5 minutes). Within that period, the service menus can be re-enabled by long pressing the **ENTER** button. If the timeout period is allowed to expire, the password entry screen will appear prior to accessing the service menus. Also, if the service menu is active when a timeout occurs, the service mode is disabled, and the display will go blank (i.e. power saving mode). Lastly, the service menu timeout is reset with each button press while the service menus are active.



4.2.8.2 Service Menu Overview

Once the correct password is entered, the main service menu is displayed as shown in the following diagram.

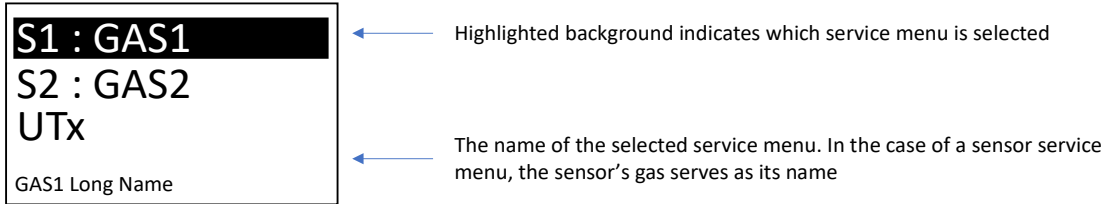

Once again, the **UP** and **DOWN** buttons can be used to navigate the list of service menus. The main service menu provides the menu items listed in the table below:

Table 4-6: Service Menu Options

Menu Item	Description
<Sensor #> : <Gas Label>	Each sensor is included in the service menu indicated by its number and gas label (Ex: S2 : CO).
UTx	Access the settings for the transmitter module through the 'UTx' menu item.
Exit	Select this menu item to exit the service menu.

To exit the Service Menu, press **DOWN** repeatedly until the end is reached and Exit is highlighted as shown below.

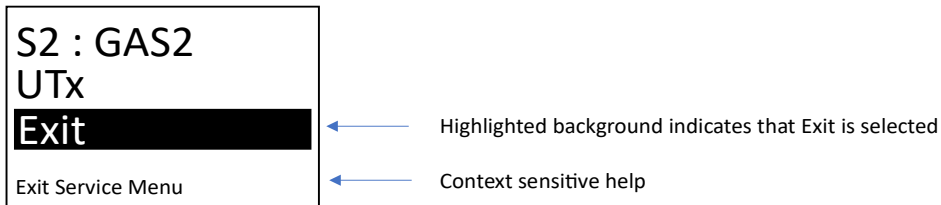

With 'Exit' highlighted (as above), press **ENTER** to exit the service mode and return back to the main info screen as shown below.

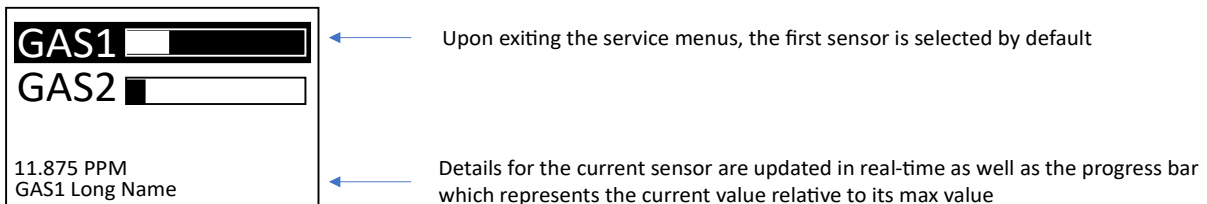

4.2.9 External Sensor Service Menu

NOTE: The Outputs menu (available from the main service menu) is used to provide supplemental configuration options that are applicable to external sensors, beyond those in the External Sensor Service menu.

4.2.9.1 External Sensor Service Menu Overview

If the **ENTER** button is pressed while the service menus are active and an external sensor is currently selected, then the following menu is shown for external sensors. This menu is common to all external sensors, therefore, selecting any external sensor will produce the same menu.

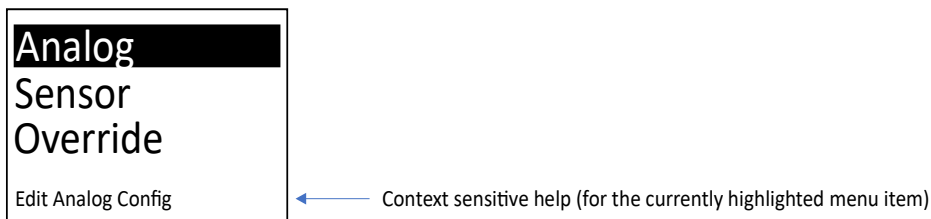

The **UP** and **DOWN** buttons can be used to navigate the list of service menus for the selected sensor. The sensor's service menu provides the following menu items:

Table 4-7: External Sensor Menu Options

Menu Item	Description
Analog	Analog configuration sub-menu for the selected sensor.
Sensor	Sensor configuration sub-menu for the selected sensor.
Override	Override sub-menu for the selected sensor.
Exit	Select this menu to return to the main service menu.

4.2.9.2 Analog Sub-Menu

If 'Analog' configuration sub-menu is activated from the sensor's service menu when an external sensor is selected, then the display will be updated to show the following sub-menu.

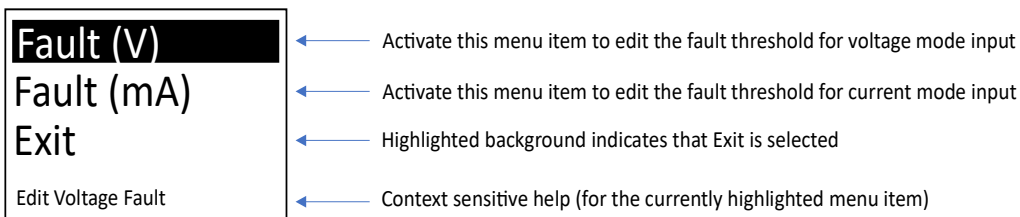



The **UP** and **DOWN** buttons can be used to navigate the list of analog configuration options for the selected external sensor. The analog configuration sub-menu is defined in the below table:

Table 4-8: Analog Sub-Menu Options

Menu Item	Description
Fault (V)	Activate this menu item to edit the fault threshold (in V) for voltage mode input.
Fault (mA)	Activate this menu item to edit the fault threshold (in mA) for current mode input.
Exit	Select this menu item to return to the sensor’s service menu. The ‘Analog’ sub-menu will be selected when the sensor’s service menu appears.

If ‘Fault (V)’ is activated from the ‘Analog’ configuration sub-menu, then the display will be updated to show the following editing screen.

← ‘Fault (V)’ serves as a label only.

← Edit the voltage fault threshold value one digit at a time using the UP/DOWN buttons. Press ENTER to advance the cursor to the next digit. Press ENTER when the last digit is highlighted to save the value.

← Context sensitive help (for the currently highlighted menu item)

When the **ENTER** button is pressed with the last digit selected, the screen will update to display the confirmation dialog (described previously). If ‘Yes’ is selected, the edit value is persisted as the new value for the voltage fault threshold for the selected external sensor. Otherwise, the edit value is rejected. In either case, the menu returns to the ‘Analog’ configuration sub-menu menu with the ‘Fault (V)’ menu item selected.

NOTE: This value only applies when the input mode is voltage mode and has a non-zero minimum input. For example, with an external sensor configured for operation between 2 - 10 V, setting a fault value of 1 V would lead to the sensor being found in a ‘FAIL’ state with an input voltage of less than 1 V.

WARNING: Entering a fault value of 0 V disables the fault check.

If ‘Fault (mA)’ is activated from the ‘Analog’ configuration sub-menu, then the display will be updated to show the following editing screen.

Fault (mA)

02.5

Enter To Adv Cursor

- ← 'Fault (mA)' serves as a label only.
- ← Edit the current fault threshold value one digit at a time using the UP/DOWN buttons. Press ENTER to advance the cursor to the next digit. Press ENTER when the last digit is highlighted to save the value.
- ← Context sensitive help (for the currently highlighted menu item)

When the **ENTER** button is pressed with the last digit selected, the screen will update to display the confirmation dialog (described previously). If Yes is selected, the edit value is persisted as the new value for the current fault threshold for the selected external sensor. Otherwise, the edit value is rejected. In either case, the menu returns to the 'Analog' configuration sub-menu menu with the 'Fault (mA)' menu item selected.

NOTE: This value only applies when the input mode is current mode and has a non-zero minimum input. For example, with an external sensor configured for operation between 4 - 20 mA, setting a fault value of 2 mA would lead to the sensor being found in a 'FAIL' state with an input current of less than 2 mA.

WARNING: Entering a fault value of 0 mA disables the fault check.

If 'Exit' is activated from the 'Analog' configuration sub-menu, then the user is returned to the sensor's service menu for an external sensor.

4.2.9.3 Sensor Sub-Menu

If the 'Sensor' sub-menu is activated from the sensor's service menu when an external sensor is selected, then the display will be updated to show the following sub-menu.

Gas Label

Eng Units

Window

Edit Gas Label

- ← Activate this menu item to edit the gas label for the selected sensor
- ← Activate this menu item to edit the engineering units for the selected sensor
- ← Activate this menu item to edit the custom filter window for the selected sensor
- ← Context sensitive help (for the currently highlighted menu item)

The **UP** and **DOWN** buttons can be used to navigate the list of sensor configuration options for the selected external sensor. The sensor configuration sub-menu is defined in the below table:

Table 4-9: Sensor Sub-Menu Options

Menu Item	Description
Gas Label	Activate this menu item to edit the gas label for the selected sensor.

Eng Units	Activate this menu item to edit the engineering units for the selected sensor.
Window	Activate this menu item to edit the custom filter window for the selected sensor.
Exit	Select this menu item to return to the sensor’s service menu. The ‘Config’ sub-menu will be selected when the sensor’s service menu appears.

4.2.9.4 Gas Label

If ‘Gas Label’ is activated from the ‘Sensor’ sub-menu, then the display will be updated to show the following editing screen.

← ‘Gas Label’ serves as a label only, therefore, this item can not be selected.

← Edit the gas label value character at a time using the **UP/DOWN** buttons. Press **ENTER** to advance the cursor to the next character. Press **ENTER** when the last character (space) is highlighted to save the value.

← Context sensitive help (for the currently highlighted menu item)

Each character can be edited to any alpha-numeric value (A-Z, 0-9) including a space. When **ENTER** button is pressed with the last non-space character highlighted, a space will be appended to the label to allow expanding the label value.

When the **ENTER** button is pressed with the last character selected and that character is a space, the screen will update to display the confirmation dialog (described previously). If ‘Yes’ is selected, the edit value is persisted as the new value for the Gas Label for the selected external sensor.

Otherwise, the edit value is rejected. In either case, the menu returns to the ‘Sensor’ configuration sub-menu menu with the ‘Gas Label’ menu item selected.

4.2.9.5 Engineering Units

If ‘ENG UNITS’ is activated from the ‘Sensor’ sub-menu, then the display will be updated to show the following editing screen.

← ‘Eng Units’ serves as a label only.

← The engineering units can be selected from a list of options using the **UP/DOWN** Buttons to cycle between each option. Press **ENTER** to save the selected options.

← Context sensitive help (for the currently highlighted menu item)

The available options for ‘ENG UNITS’ are listed in the following table.

Table 4-10: Engineering Unit Options

Menu Item	Description
PPB	Parts per Billion
PPM	Parts per Million
% LEL	Percent of Lower Explosive Limit
% VOL	Percent by Volume
Volt	Voltage
% FS	Percent of Full Scale
% LFL	Percent of Lower Flammable Limit

When the **ENTER** button is pressed, the screen will update to display the confirmation dialog (described previously).

4.2.9.6 External Sensor Custom Window Average

Window is a custom average filter for gas readings, where the averaging "window" can be selected from a multiplier of 2-60. This refers to the "Custom" average that can be seen through the detailed sensor screen for each sensor. The averaging time ranges between 30–900, minutes in increments of 15 minutes. For example, a multiplier of 3 would correspond to an averaging window of 45 minutes.

If 'Window' is activated from the external 'Sensor' sub-menu, then the display will be updated to show the following editing screen.

← 'Window' serves as a label only.

← Edit the window filter value one digit at a time using the UP/DOWN buttons. Press **ENTER** to advance the cursor to the next digit. Press **ENTER** when the last digit is highlighted to save the value.

← Context sensitive help

When the **ENTER** button is pressed with the last digit selected, the screen will update to display the confirmation dialog (described previously). If 'Yes' is selected, the edit value is persisted as the new value for the filter window for the selected external sensor. Otherwise, the edit value is rejected. In either case, the menu returns to the 'Sensor' sub-menu with the 'Window' menu item selected.

4.2.9.7 Simulation Of Gas Levels (External Sensors)

The External Sensor Menu allows the current gas reading of an external sensor to be overridden by a simulated gas level. This may be useful during the system commissioning to verify operation of the Monitor or alarm relays.

Table 4-11: External Override Sub-Menu Options



Menu Item	Description
Sim Enable	Menu item for turning the external gas override value on/off.
Sim Gas	Allows an external override value to be selected (only applied if Sim Enable set to “Enabled”).
Exit	Select this menu item to return to the external sensor service menu.

4.2.9.8 Override

If ‘Override’ sub-menu is activated from the external sensor’s service menu, then the display will be updated to show the following sub-menu.

The screenshot shows a menu with the following items: Sim Enable (highlighted), Sim Gas, Exit, and Edit Sim Enable. Annotations with arrows point to each item:

- ← Sim Enable: Activate this menu item to edit the simulated gas enable flag for the selected sensor
- ← Sim Gas: Activate this menu item to edit the simulated gas concentration for the selected sensor
- ← Exit: Activate this menu item to exit the “Override” sub-menu
- ← Edit Sim Enable: Context sensitive help (for the currently highlighted menu item)

4.2.9.9 Sim Enable

If ‘Sim Enable’ is activated from the ‘Override’ sub-menu, then the display will be updated to show the following editing screen.

The screenshot shows the 'Sim Enable' editing screen with 'Disabled' highlighted. Annotations with arrows point to the screen:

- ← Disabled: Defaults to the current value of the Sim Enable flag. Use UP/DOWN arrow buttons to toggle between Disabled and Enabled. Press ENTER button to confirm selection.
- ← Press Enter to Save: Context sensitive help (for the currently highlighted menu item)

When the **ENTER** button is pressed, the confirmation screen (described previously) is displayed. If ‘Yes’ is selected, the edit value is persisted as the new value for the Sim Enable flag. Otherwise, the edit value is rejected. In either case, the menu returns to the Override sub-menu menu with the ‘Sim Enable’ menu item selected.

4.2.9.10 Sim Gas

If ‘Sim Gas’ is activated from the ‘Override’ sub-menu, then the display will be updated to show the following editing screen.

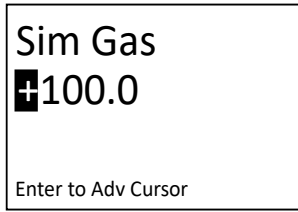

- ← 'Sim Gas' serves as a label only.
- ← Edit the simulated gas value one digit at a time using the UP/DOWN buttons. Press ENTER to advance the cursor to the next digit. Press ENTER when the last digit is highlighted to save the value.
- ← Context sensitive help

When the **ENTER** button is pressed with the last digit highlighted, the confirmation screen (described previously) is displayed. If 'Yes' is selected, the edit value is persisted as the new value for the Sim Gas concentration value. Otherwise, the edit value is rejected. In either case, the menu returns to the Override sub-menu menu with the 'Sim Gas' menu item selected.

Selected 'Exit' from the 'Override' sub-menu returns the user to the sensor's service menu with the 'Override' menu item selected.

4.2.10 Transmitter Service Menu

If the 'UTx menu item is activated from the main service menu via the **ENTER** button, then UTx service menu will appear on the display as shown in the following diagram.

The **UP** and **DOWN** buttons can be used to navigate the list of service menus for the UTx. The following table outlines all the menu items from the UTx menu:

Table 4-12: Transmitter Service Menu

Menu Item	Description
Sensors	Select this menu item to activate the Sensors sub-menu.
Alarms	Select this menu item to activate the Alarms sub-menu.
Relays	Select this menu item to activate the Relays sub-menu.
Outputs	Select this menu item to activate the Outputs sub-menu.
Test	Select this menu item to toggle the test enable flag.
Buzzer	Select this menu item to toggle the low alarm buzzer enable flag.
Ack Timer	Select this menu item to adjust the buzzer acknowledgement timeout (30 – 120 seconds).
Reset	Select this menu item to trigger a software reset of the UTx.
Exit	Select this menu item to return to the main service menu. The menu item for the UTx will be selected when the main service menu appears.

4.2.10.1 Transmitter Sensors Settings

From the UTx service menu, selecting 'Sensors' will update the display to show the following sub-menu.

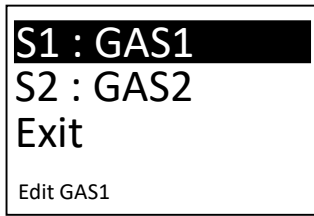

← Context sensitive help (for the currently highlighted menu item)

The **UP** and **DOWN** buttons can be used to navigate the list of configured sensors for the sensors sub-menu. The table below outlines all the menu items from the sensors sub-menu:

Table 4-13: Sensor Module Configuration Menu

Menu Item	Description
S1 : GAS1	Select this menu item to activate the configuration sub-menu for sensor 1.
S2 : GAS2	Select this menu item to activate the configuration sub-menu for sensor 2.
Exit	Select this menu item to return to the UTx service menu.

4.2.10.2 Sensor Alarm Configuration Sub-Menu

Selecting a sensor from the ‘Sensors’ sub-menu (ex: S1 : GAS1) will update the display to show the following sub-menu.

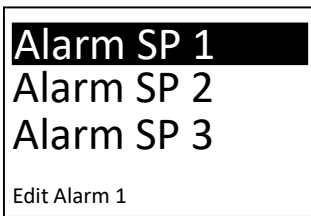

← Context sensitive help (for the currently highlighted menu item)

The **UP** and **DOWN** buttons can be used to navigate the list of menus for the ‘Sensors’ sub-menu. The below table outlines all the menu items from the sensor sub-menu:

Table 4-14: Sensor Alarm Configuration

Menu Item	Description
Alarm SP 1-3	Select this menu item to edit the alarm setpoints for the selected alarm (1-3).



Alarm Hyst	Select this menu item to edit the alarm hysteresis. This hysteresis value is applied to all alarm setpoints.
Zero Buff	Select this menu item to edit the zero-buffer level for the display of small gas concentrations.
Cal Freq	Select this menu item to edit the time period between re-calibrations.
Exit	Select this menu item to return to the Sensors sub-menu.

4.2.10.2.1 Setpoint

If 'Alarm SP 1' is activated from the sensor alarm configuration sub-menu, then the display will be updated to show the following editing screen.

← 'Alarm SP 1' serves as a label only.

← Edit the alarm 1 setpoint value one digit at a time using the UP/DOWN buttons. Press ENTER to advance the cursor to the next digit. Press ENTER when the last digit is highlighted to save the value.

← Context sensitive help

When the **ENTER** button is pressed, the screen will update to display the confirmation dialog (described previously).

The same process is repeated for Alarm SP 2 and Alarm SP 3. In all cases, once the confirmation dialog is reached, regardless of which option it selected, the user is returned back to the Sensors sub-menu.

4.2.10.2.2 Alarm Hysteresis

If 'Alarm Hyst' is activated from the sensor sub-menu, then the display will be updated to show the following editing screen.

← 'Alarm Hyst' serves as a label only.

← Edit the alarm hysteresis setpoint value one digit at a time using the UP/DOWN buttons. Press ENTER to advance the cursor to the next digit. Press ENTER when the last digit is highlighted to save the value.

← Context sensitive help

When the **ENTER** button is pressed, the screen will update to display the confirmation dialog (described previously). If 'Yes' is selected, the edit value is persisted as the new value for the Alarm Hysteresis for the selected sensor. Otherwise, the edit value is rejected. In either case, the menu returns to the Sensor sub-menu menu with the 'Alarm Hyst' menu item selected.

4.2.10.2.3 Zero Buffer

If 'Zero Buff' is activated from the sensor sub-menu, then the display will be updated to show the following editing screen.

When the **ENTER** button is pressed, the screen will update to display the confirmation dialog (described previously). If Yes is selected, the edit value is persisted as the new value for the Zero Buffer for the selected sensor. Otherwise, the edit value is rejected. In either case, the menu returns to the Sensor sub-menu menu with the 'Zero Buff' menu item selected.

4.2.10.2.4 Calibration Frequency

If 'Cal Freq' is activated from the sensor sub-menu, then the display will be updated to show the following editing screen.

The available options for 'Cal Freq' are listed in the table below.

Table 4-15: Calibration Frequency Configuration

Menu Item	Description
OFF	Next calibration due date is not calculated.
3 Months	Next calibration due date is calculated as 3 months from last calibration timestamp.
4 Months	Next calibration due date is calculated as 4 months from last calibration timestamp.
6 Months	Next calibration due date is calculated as 6 months from last calibration timestamp.
12 Months	Next calibration due date is calculated as 12 months from last calibration timestamp.

When the **ENTER** button is pressed, the screen will update to display the confirmation dialog (described previously).

4.2.10.3 Transmitter Alarm Settings

From the UTx service menu, selecting 'Alarms' will update the display to show the following sub-menu.

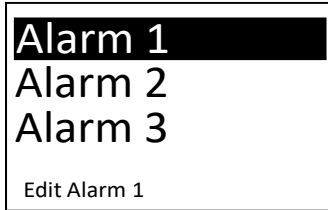

← Context sensitive help (for the currently highlighted menu item)

The **UP** and **DOWN** buttons can be used to navigate the list of menus for the Alarms sub-menu. The table below outlines all the menu items from the Alarms sub-menu:

Table 4-16: Transmitter Alarm Settings

Menu Item	Description
Alarm 1-18	Select this menu item to activate the configuration sub-menu for the selected alarm.
Exit	Select this menu item to return to the UTx service menu. The alarms menu item will be selected when the UTx service menu appears.

4.2.10.4 Alarm Sub-Menu

Selecting an alarm from the alarms sub-menu will update the display to show the following:

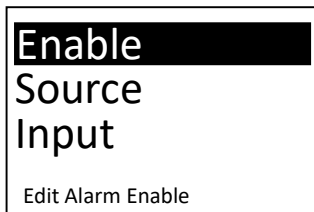

← Context sensitive help (for the currently highlighted menu item)

The below table outlines all the menu items from the alarm sub-menu:

Table 4-17: Transmitter Alarm Sub-Menu Settings

Menu Item	Description
Enable	Select this menu item to edit the alarm's enable state.
Source	Select this menu item to edit the alarm's source (i.e. from the available sensors).
Input	Select this menu item to edit the alarm's input value.
Level	Select this menu item to edit the alarm's setpoint.
Type	Select this menu item to edit the alarm's type (increasing or decreasing).

Output	Select this menu item to edit the alarm's trigger output (i.e. activate which relays).
Act Delay	Select this menu item to edit the alarm's act delay in terms of seconds.
Min Run	Select this menu item to edit the alarm's minimum run time in terms of seconds.
Exit	Select this menu item to return to the Alarms sub-menu.

4.2.10.4.1 Enable

If 'Enable' is activated from the alarm sub-menu, then the display will be updated to show the following editing screen.

'Enable' serves as a label only.

Defaults to the current value of the Enable flag. Use UP/DOWN arrow buttons to toggle between Disabled and Enabled. Press ENTER button to confirm selection.

Context sensitive help

When the **ENTER** button is pressed, the confirmation screen (described previously) is displayed.

4.2.10.4.2 Source

If 'Source' is activated from the alarm sub-menu, then the display will be updated to show the following editing screen.

'Source' serves as a label only.

The source can be selected from a list of sensors. Cycle through all the values using the UP/DOWN buttons.

Context sensitive help

The available options for 'Source' are equal to the list of sensors currently configured for the UTx. The label for each sensor is dynamically assigned to S<n> : GAS<n> where n represents the sensor's 1 base index and GAS represents the sensor's gas name in short form.

When the **ENTER** button is pressed, the screen will update to display the confirmation dialog (described previously).

4.2.10.4.3 Input

If 'Input' is activated from the alarm sub-menu, then the display will be updated to show the following editing screen.

← 'Input' serves as a label only.

← The input can be selected from a list of options using the UP/DOWN buttons to cycle between each option. Press ENTER to save the selected options.

← Context sensitive help

The available options for 'Input' are listed in the table below:

Table 4-18: Alarm Input Options

Menu Item	Description
Inst. Value	Instantaneous gas value, updated once per second.
15m Avg	Gas concentration averaged over the past 15 minutes.
8h Avg	Gas concentration averaged over the past 8 hours.
Custom	Gas concentration averaged over a custom filter window (15-minute multipliers of 2-60, refer to the External Sensor Custom Window Average section for details.
Daily Peak	Daily peak value.

When the **ENTER** button is pressed, the screen will update to display the confirmation dialog (described previously).

4.2.10.4.4 Level

If 'Level' is activated from the alarm sub-menu, then the display will be updated to show the following editing screen.

← 'Level' serves as a label only.

← The level can be selected from a list of options using the UP/DOWN buttons to cycle between each option. Press ENTER to save the selected options.

← Context sensitive help

The available options for ‘Level’ are listed the below table.

Table 4-19: Alarm Setpoint Options

Menu Item	Description
Alarm SP 1	Alarm setpoint 1 from the selected source.
Alarm SP 2	Alarm setpoint 2 from the selected source.
Alarm SP 3	Alarm setpoint 3 from the selected source.

When the **ENTER** button is pressed, the screen will update to display the confirmation dialog (described previously).

4.2.10.4.5 Type

If ‘Type’ is activated from the alarm sub-menu, then the display will be updated to show the following editing screen.

← ‘Type’ serves as a label only.

← The type can be selected from a list of options using the **UP/DOWN** buttons to cycle between each option. Press **ENTER** to save the selected options.

← Context sensitive help

The available options for ‘Type’ are listed in the table below:

Menu Item	Description
Increasing	Alarm is triggered when alarm exceeds its threshold in an increasing direction.
Decreasing	Alarm is triggered when alarm exceeds its threshold in a decreasing direction.

When the **ENTER** button is pressed, the screen will update to display the confirmation dialog (described previously).

4.2.10.4.6 Output

If ‘Output’ is activated from the alarm sub-menu, then the display will be updated to show the following editing screen.

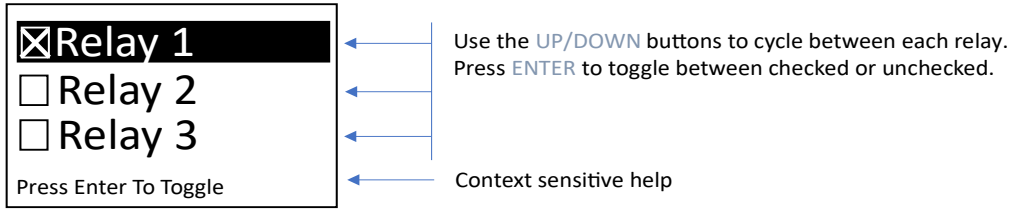

The available options for ‘Output are ‘Local’ and ‘Relay 1’ through ‘Relay 5’. If the checkbox next to the relay is checked, then that relay will activate when the associated alarm is active. Otherwise, the relay will not activate.

NOTE: Relays 3 through 5 are unavailable in the AMC-1BREF Series. Any attempt to toggle the state of a checkbox associated with an unavailable relay will be ignored.

When the **ENTER** button is pressed with ‘Done’ selected, the screen will update to Transmitter Alarm Sub-Menu.

4.2.10.4.7 Act Delay

If ‘Act Delay’ is activated from the Alarm sub-menu, then the display will be updated to show the following editing screen.

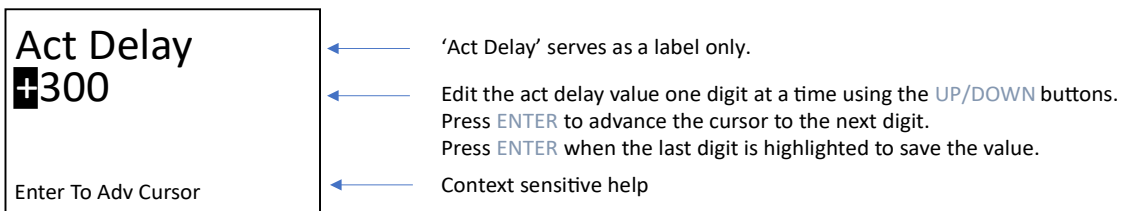

When the **ENTER** button is pressed while the last digit is highlighted, the screen will update to display the confirmation dialog (described previously).

4.2.10.4.8 Min Run

If ‘Min Run’ is activated from the Alarm sub-menu, then the display will be updated to show the following editing screen.

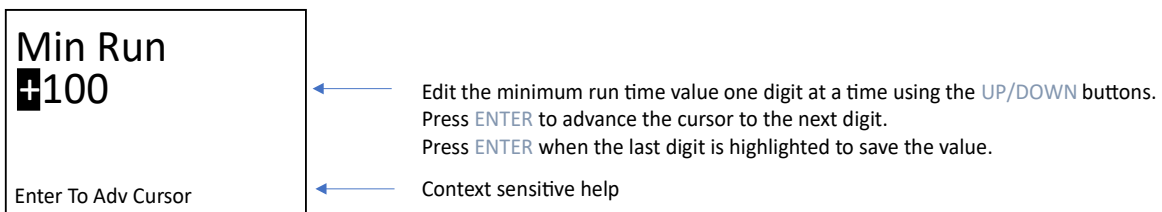

When the **ENTER** button is pressed while the last digit is highlighted, the screen will update to display the confirmation dialog (described previously).

4.2.10.5 Transmitter Relay Settings

From the UTx service menu, selecting 'Relays' will update the display to show the following sub-menu.

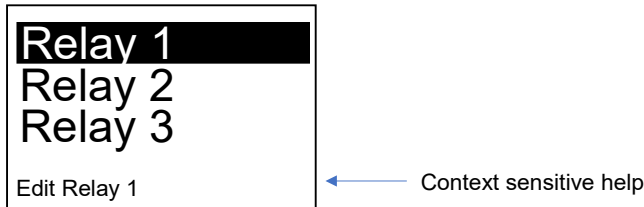

The **UP** and **DOWN** buttons can be used to navigate the list of menus for the Alarms sub-menu.

The following table outlines all the menu items from the Alarms sub-menu:

Menu Item	Description
Relay 1-5	Selecting this menu item to activate the configuration sub-menu for the selected relay (ranging from 1 to 5).
Exit	Select this menu item to return to the UTx service menu. The Relays menu item will be selected when the UTx service menu appears.

Selecting a relay from the alarms sub-menu will update the display to show the following:

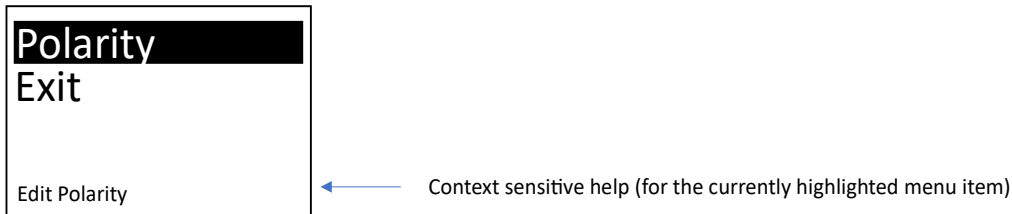

The table below outlines all the menu items from the relay sub-menu:

Menu Item	Description
Polarity	Select this menu item to edit the relay's polarity setting.
Exit	Select this menu item to return to the Relays sub-menu.

If 'Polarity' is activated from the relay sub-menu, then the display will be updated to show the following editing screen.

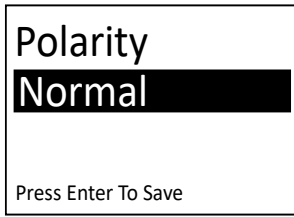

- ← 'Polarity' serves as a label only.
- ← The polarity can be selected from a list of options using the **UP/DOWN** buttons to cycle between each option. Press **ENTER** to save the selected options.
- ← Context sensitive help

The available options for 'Polarity' are listed in the table below:

Menu Item	Description
Normal	Relay coil is energized when associated alarm is active. Otherwise, the relay coil is de-energized.
Reverse	Relay coil is de-energized when associated alarm is active. Otherwise, the relay coil is energized.

When the **ENTER** button is pressed, the screen will update to display the confirmation dialog (described previously).

NOTE: The monitor system configuration is factory-set to use the reverse setting for the fail-safe mode. Fail safe mode provides continuity between COM to NC during WARN/ALARM/FAULT and power failure, and the associated relay LED indicator will be off.

4.2.10.6 Outputs

Analog output configuration is handled via the Outputs menu available from the main service menu. With the Outputs menu it is possible to configure the analog output to use multiplexed sensor sources to determine the output response; this section concludes with an example. Once in the Outputs menu, the **UP** and **DOWN** buttons can be used to navigate the list of available analog outputs to be configured.

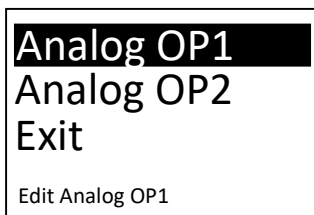

- ← Context sensitive help (for the currently highlighted menu item)

Table 4-20: Outputs Sub-Menu

Menu Item	Description
-----------	-------------



Source	Allows the analog output channel to be driven based on desired gas sources. With this menu item, it is possible to multiplex several of the available gases together to drive the output.
Mode	Used to select between voltage or current analog output modes.
Range	Can be used to adjust the output range. The units in the menu are either V or mA, depending on the selection chosen with the Mode menu item.

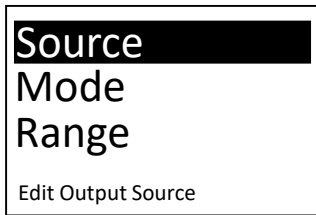

← Context sensitive help (for the currently highlighted menu item)

4.2.10.6.1 Source

When the **ENTER** button is pressed with Source selected, the list of available gases will be presented. A checkbox to the left of each gas label indicates if a gas is being used in the calculation of the analog output.

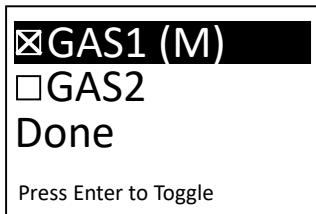

← Context sensitive help (for the currently highlighted menu item)

To the right of each enabled gas an “M” or “A” in brackets denotes which gas concentration is used in scaling the output response. The “M” indicates that the maximum supported gas concentration of the sensor is used in scaling the output response. An “A” indicates that the gas concentration tied to the high alarm (Alarm SP 3, see the **‘Transmitter Sensor Settings’** section, is used as max scale in the calculation of the analog output response.

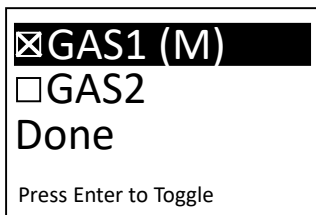

← Context sensitive help (for the currently highlighted menu item)

When the **ENTER** button is pressed with an unchecked gas selected, a screen will be presented to allow the selection between the max gas concentration (“MAX”) or Alarm SP 3 (“HI ALARM”). Use the **UP** and **DOWN** buttons to select between the two options, and press **ENTER** to confirm the selection. This will cause a return to Source sub-menu with the gas as checked. Pressing the **ENTER** button on an already checked gas will cause it to become unchecked and clear the “M” or “A” setting.

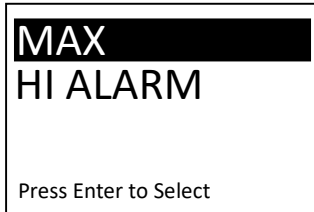

← Press **UP/DOWN** to toggle between options.

← Context sensitive help (for the currently highlighted menu item)

4.2.10.6.2 Mode

From the Outputs menu, when the **ENTER** button is pressed with Mode selected, a menu option to select between and analog output mode of voltage or current will be presented. Use the **UP** and **DOWN** buttons to select between the two options, and press **ENTER** to confirm the selected mode.

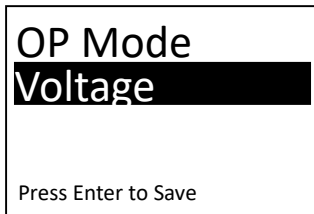

← Press **UP/DOWN** to toggle between voltage and current output modes.

← Context sensitive help (for the currently highlighted menu item)

4.2.10.6.3 Range

From the Outputs menu, when the **ENTER** button is pressed with Range selected, a sub-menu to configure the minimum and maximum analog output response will become available. The engineering unit (V or mA) displayed in the Output Min/Max menu items will reflect the analog output mode selected with the Mode menu item.



← Context sensitive help (for the currently highlighted menu item)

The permitted analog output range for voltage mode is between 0-10V.



Min (V)
00
Enter To Adv Cursor

- ← 'Min (V)' serves as a label only.
- ← Edit the window filter value one digit at a time using the UP/DOWN buttons. Press ENTER to advance the cursor to the next digit. Press ENTER when the last digit is highlighted to save the value.
- ← Context sensitive help

Max (V)
10
Enter To Adv Cursor

- ← 'Max (V)' serves as a label only.
- ← Edit the window filter value one digit at a time using the UP/DOWN buttons. Press ENTER to advance the cursor to the next digit. Press ENTER when the last digit is highlighted to save the value.
- ← Context sensitive help

The permitted analog output range for current mode is between 0-20mA.

MIN (mA)
00
Enter To Adv Cursor

- ← 'MIN (mA)' serves as a label only.
- ← Edit the window filter value one digit at a time using the UP/DOWN buttons. Press ENTER to advance the cursor to the next digit. Press ENTER when the last digit is highlighted to save the value.
- ← Context sensitive help

MAX (mA)
10
Enter To Adv Cursor

- ← 'MAX (mA)' serves as a label only.
- ← Edit the window filter value one digit at a time using the UP/DOWN buttons. Press ENTER to advance the cursor to the next digit. Press ENTER when the last digit is highlighted to save the value.
- ← Context sensitive help

4.2.10.6.4 Multiplexing Example

With an overview of the Outputs menu complete, it is worthwhile to show an example of how a multiplexed sensor configuration can be used to drive the analog output. In this example, the following configuration is used:

- Voltage output mode on OP1.
- 2-10V range selected for OP1.
- GAS1, with a max gas concentration of 100 PPM, and Alarm SP 3 of 100 PPM.
- GAS2, with a max gas concentration of 10 PPM, and Alarm SP 3 of 3 PPM.

- GAS1 and GAS2 are to be multiplexed; whichever gas has a higher percentage of maximum scale is to drive the output.
- GAS1 is using the max gas concentration for scaling (“M”), whereas GAS2 is using Alarm SP 3 (“A”).

Suppose GAS1 has a present reading of 7 PPM, and GAS2 has a present reading of 0.5 PPM. GAS1 has a percent of max scale of $7/100=0.07$. GAS2 has a percent of max scale of $0.5/3=0.16$. As a result, it is GAS2 that presently determines the analog output response.

The range selected for voltage mode is $(10V - 2V) = 8V$. Accounting for the output offset (Output Min) of 2V, the analog output value will be found to be $2V + 0.16 * 8V = 3.33 V$.

4.2.10.7 Buzzer

From the UTx service menu, selecting ‘Buzzer’ will update the display to show the following:

← ‘Buzzer’ serves as a label only.

← The buzzer activation level can be selected from a list of options using the UP/DOWN buttons to cycle between each option. Press ENTER to save the selected options.

← Context sensitive help

The available options for ‘Buzzer’ are listed in the table below:

Table 4-21: Buzzer Menu

Menu Item	Description
None	Disable local buzzer completely.
Alarm	Local buzzer sounds for alarm level and fault.
All Levels	Local buzzer sounds for warning, alarm, high alarm levels, and fault.

4.2.10.8 Acknowledgement Timer

From the UTx service menu, selecting ‘Ack Timer’ will update the display to show the following:

← ‘Ack Timer’ serves as a label only.

← Edit the activation timer value one digit at a time using the UP/DOWN buttons. Press ENTER to advance the cursor to the next digit. Press ENTER when the last digit is highlighted to save the value.

← Context sensitive help



When the **ENTER** button is pressed while the last digit is highlighted, the screen will update to display the confirmation dialog (described previously).

The allowable values for the activation timer are 30-120 seconds. During an alarm state, the local buzzer may be silenced for a period equal to activation timer, by pressing the **ENTER** button.

4.2.10.9 RTC Date & Time

The main service menu Date and Time items can be used to update the on-board real-time clock (RTC). The RTC runs on battery power when main power is unavailable. These menus provide a mechanism to update the date and time, for example, in the event of low battery during a power outage.

Use the **UP** and **DOWN** buttons to scroll through available year, month, and day options. A short press of the **ENTER** button will advance to the next digit. A long press of the **ENTER** button will return to the previous digit. Press the **ENTER** button on the last digit to proceed to the confirmation Save dialog.

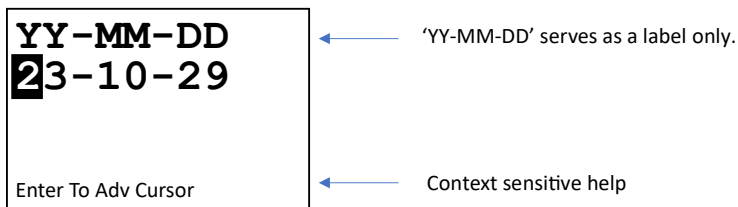

Button presses for Time menu behave in the same manner as the Date menu. Note that it is only possible to update the RTC hour and minute currently.

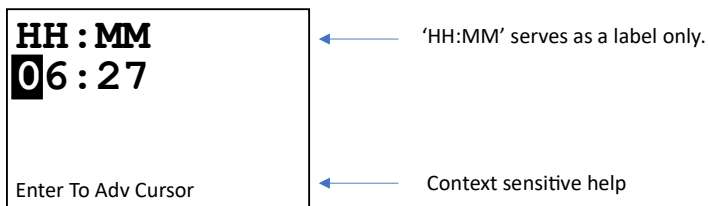

5 Maintenance

Maintenance is a crucial activity that should be done at the proper time intervals, which are discussed below.

5.1 General

The Monitor should be cleaned (brushed or wiped) as required, depending on the rate of accumulation of any dust or dirt.

To avoid damage, the unit **MOST NOT** be submerged, hosed, or splashed with any liquids. Ensure the green indicators (LEDs) are slowly blinking to indicate a healthy state.

5.2 Verification of Operation

Verification of operation should be performed at least once every 6 months. For highly demanding applications more frequent verification is recommended.

5.2.1 LED/Relay Activation Test

The Main Service Menu allows the activation of all relays and LEDs, regardless of alarm state. This may be useful during system configuration to verify operation of the LEDs and relays, as well as to verify that the polarity settings are correct.

From the Main Service Menu, selecting 'Test' will update the display to show the following:

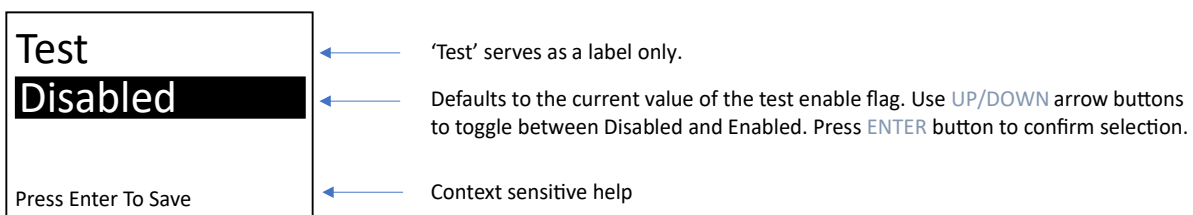

When the **ENTER** button is pressed, the confirmation screen (described previously) is displayed.

In addition to activating all relays (taking into account polarity settings), all display LEDs will appear solid white, if functional.



6 Troubleshooting

6.1 Symptoms and Corrective Actions

Table 6-1: Troubleshooting

Symptom	Possible Cause	How to Verify	Corrective Action
Buzzer or Relays Not Activating.	Bad Connection to Buzzer or Relays.	No continuity between COM and NO Bus Module terminals.	Re-seat wiring connections for buzzer and relay coils.
	Configuration Incorrect.	No continuity between Relay Coil connection and Relay Coils.	Check UTx > Buzzer menu parameters. Check if either Alarm or All Levels are selected in item.
			Check UTx > Alarms > Alarm 1/2/3/4 > Output menu parameters; ensure Relays 1 and 2 are checked (enabled).
			The Relay 1 coil is energized during the WARN state for AI1, while the Relay 2 coil is energized during the ALARM state for AI1.
			Alarm 1 is used to control Relay 1 for AI1. Alarm 2 is used to control Relay 2 for AI1.

7 Menu Flow Diagrams

7.1 Main Screen / Password Flow

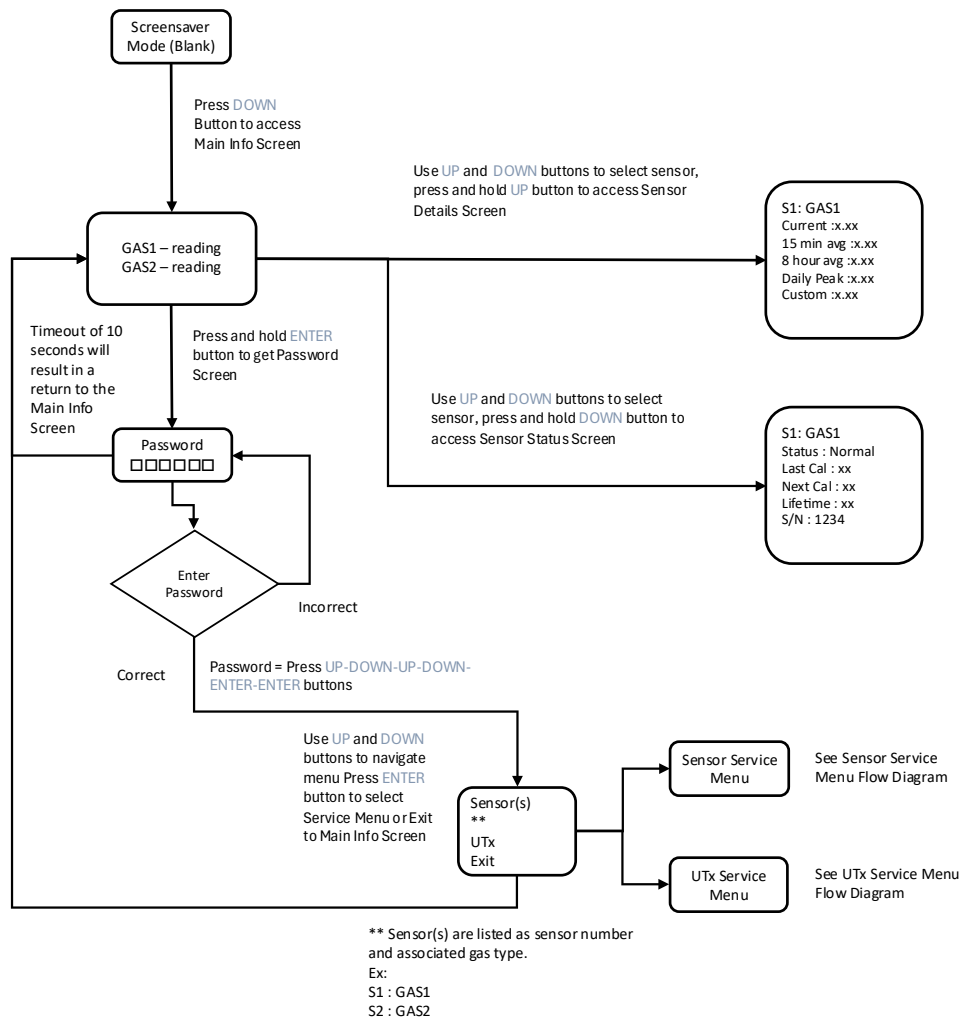

Figure 7-1: Main Screen / Password Flow

7.2 UTx Service Menu

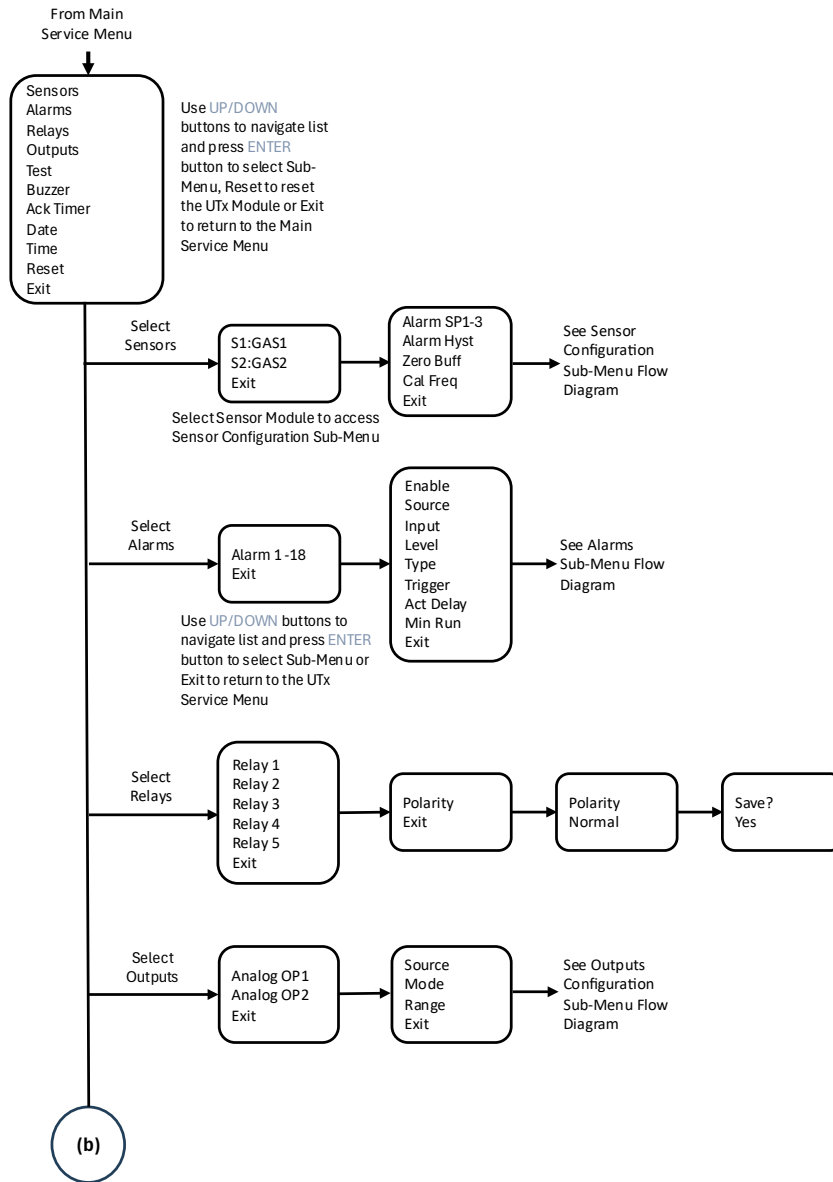

Figure 7-2: Service Menu Flow Diagram (a)

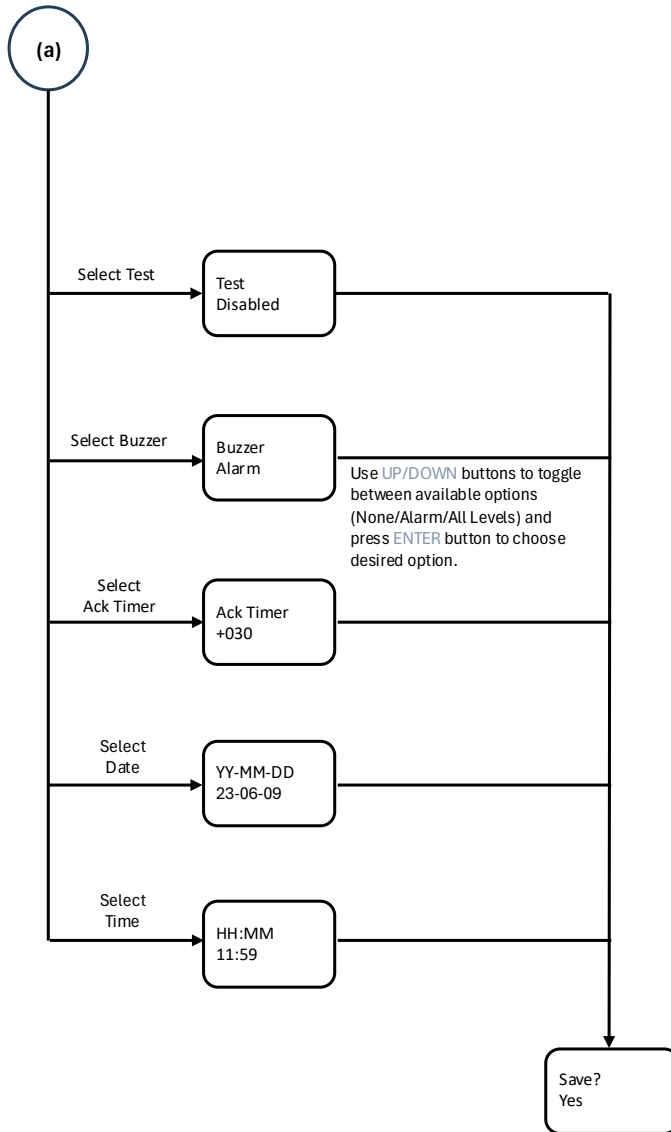

Figure 7-3: UTx Service Menu Flow Diagram (b)

7.3 Sensor Service Menu

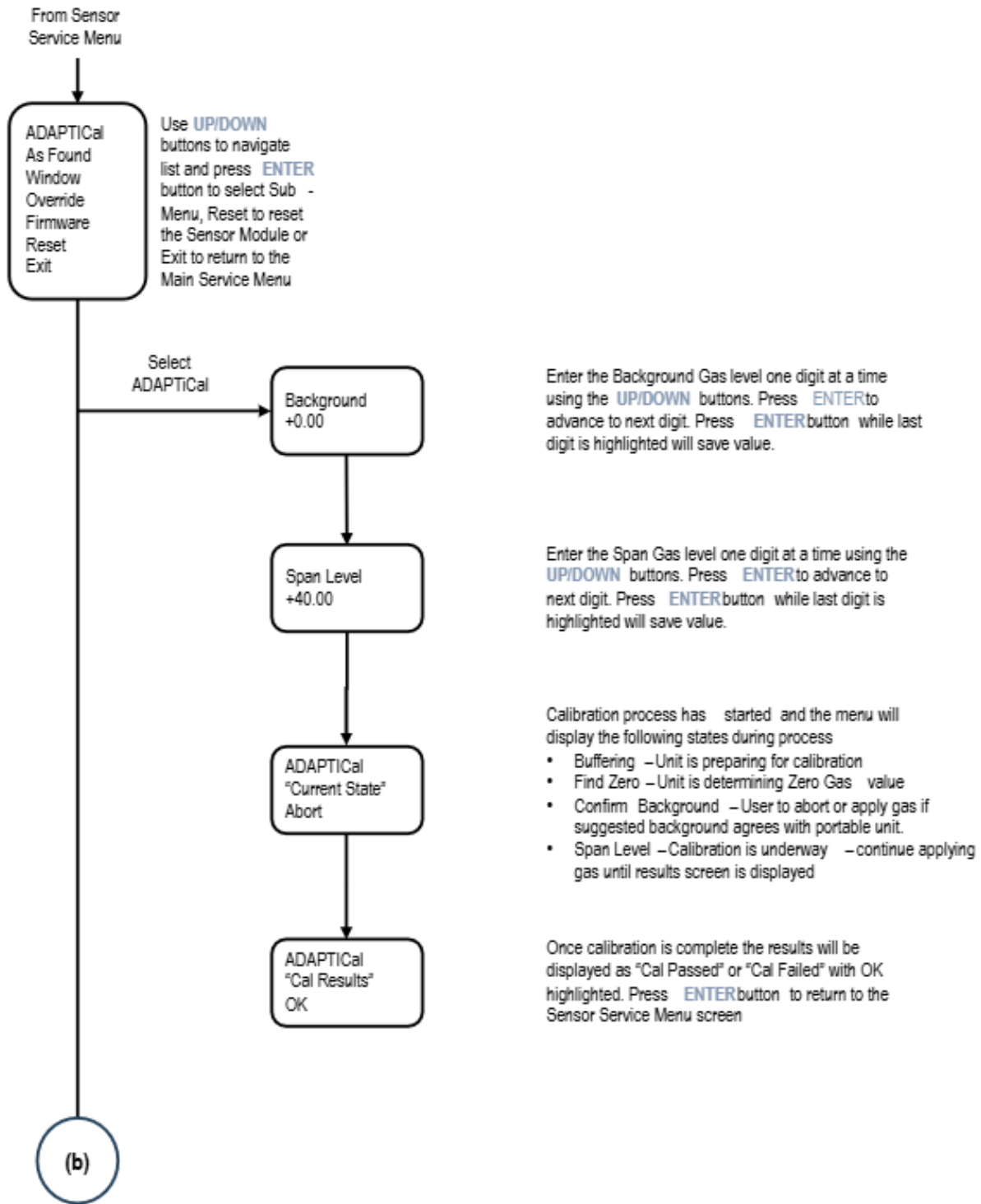

Figure 7-4: Sensor Service Menu (a)

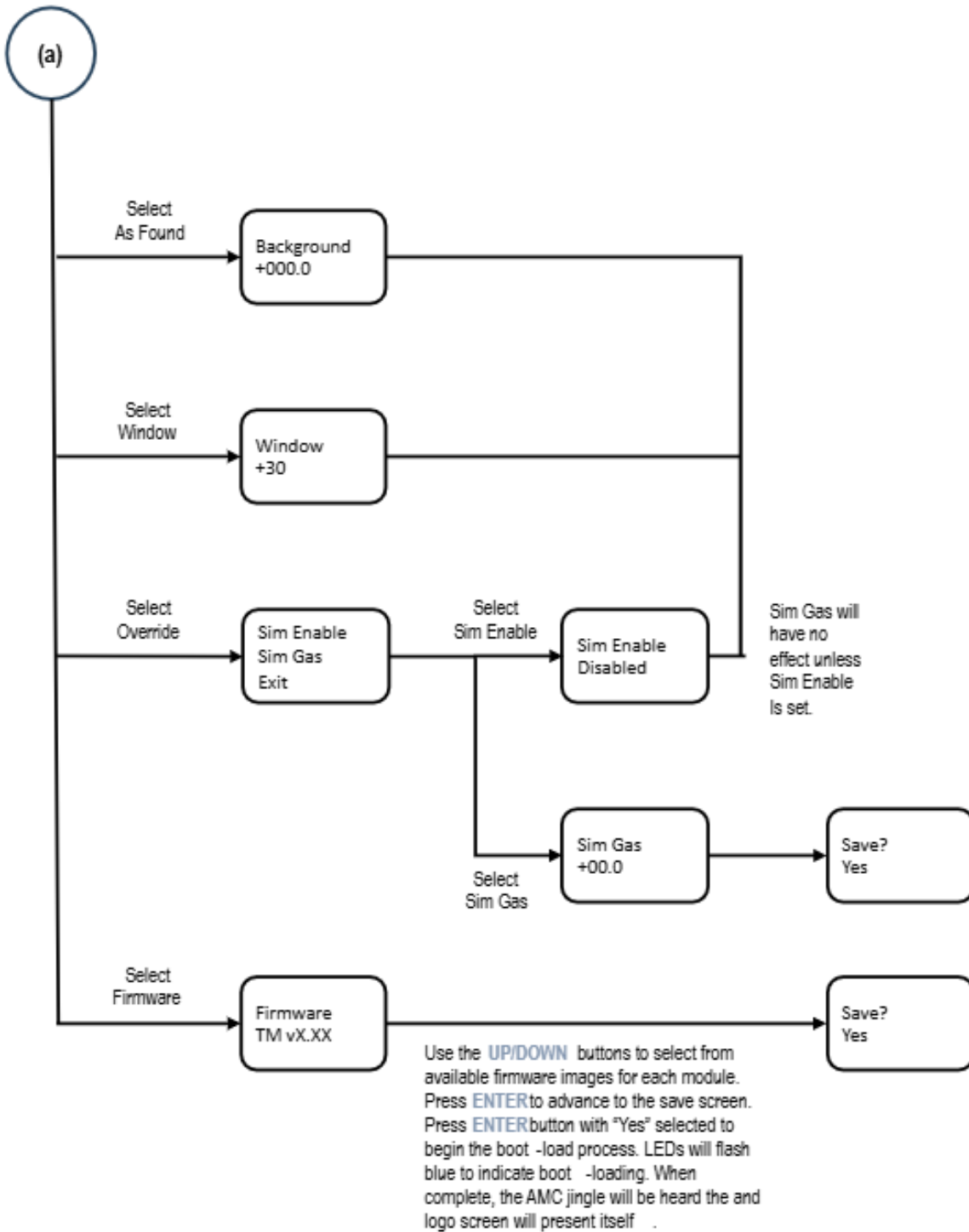

Figure 7-5: Sensor Service Menu (b)

7.4 Alarm Menu

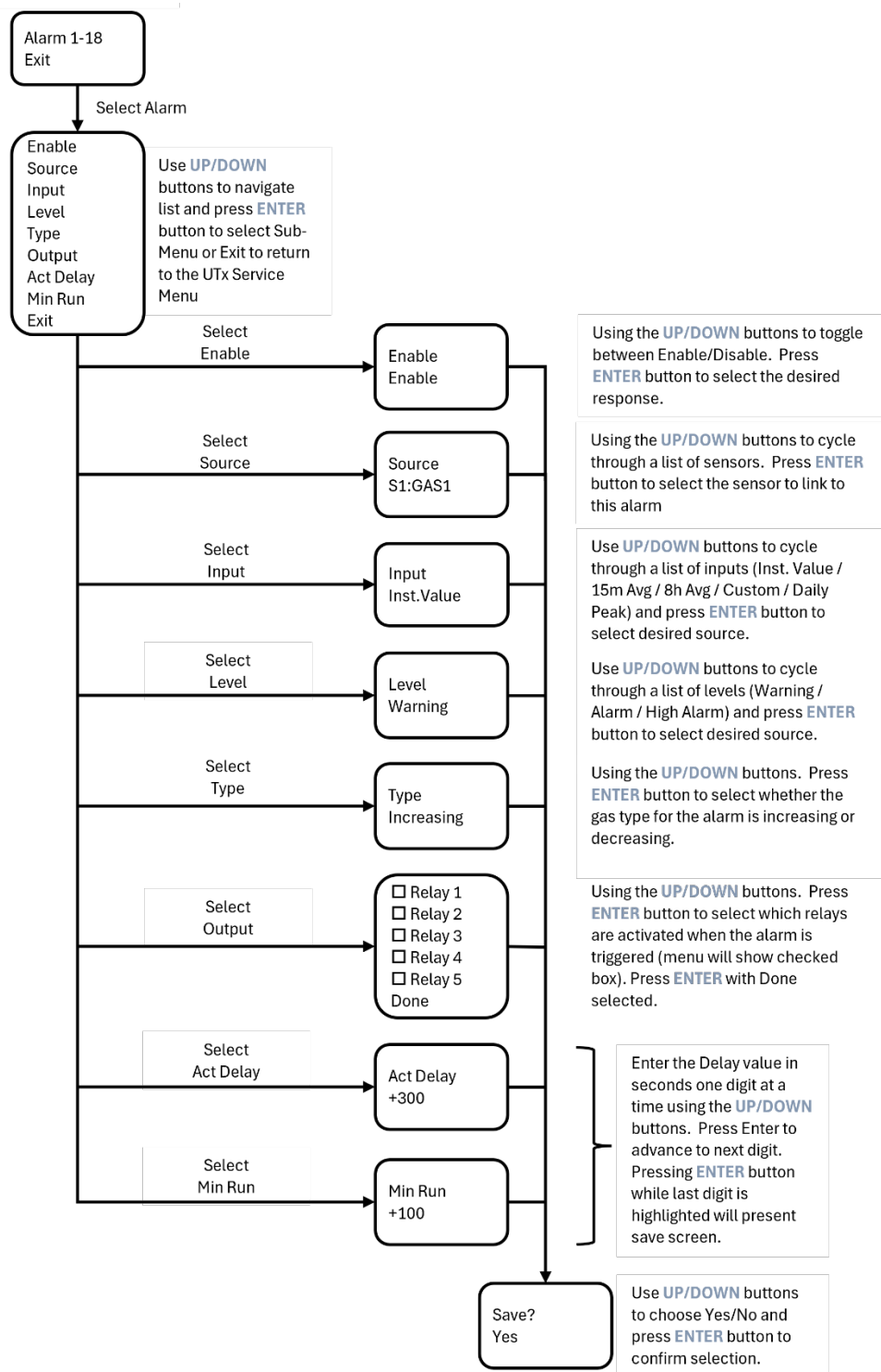

Figure 7-6: Alarm Menu Flow Diagram

7.5 Outputs

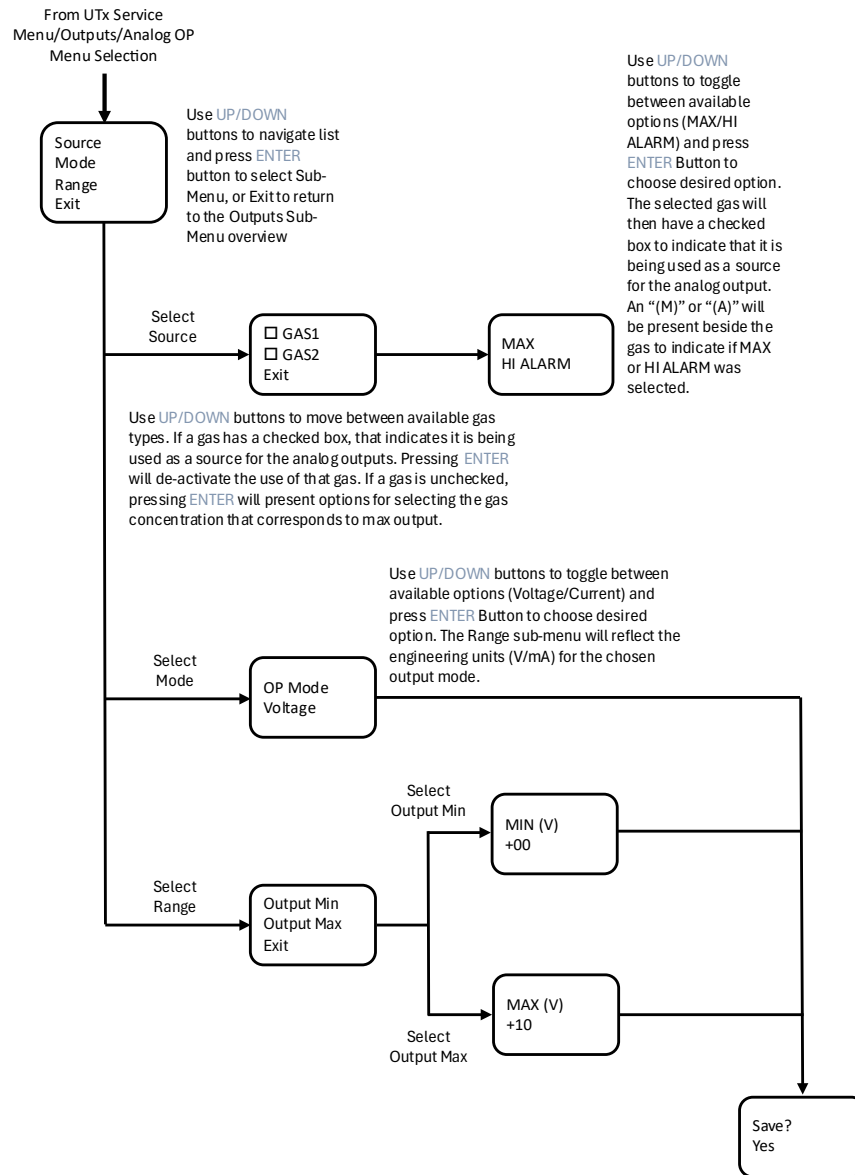

Figure 7-7: Outputs Menu Flow Diagram



8 Revision History

8.1 Document Revision History

Table 8-1: Document Revision History

Revision	Release Date	Change Description
A	September 2025	Initial Release