

# AMC-210 Series

## Electrochemical Sensor/Transmitter

Accuracy, low current consumption, and a simple two wire installation make these units an ideal solution for use with Armstrong Monitoring panels or 3rd party control systems to monitor toxic gases.

The AMC-210 series is an industry leader for flexibility in both sensor and enclosure options.

**Detectable Gas:** See Below

**Range:** See Below

**Signal Output:** 4-20 mA

**Sensor Type:** Electrochemical cell

**Enclosure:** As identified below

**Voltage Requirement:** 12-30 VDC with 250 ohm load

**Installation Wiring:** Twisted pair shielded cable

**Linearity:** Linear

**Sensor Element Warranty:** One year



Gas	XX	Sensor Type (Y)	Notes
Ammonia	(86)	Y = A	0-100 PPM / -40°C
		Y = B	0-1000 PPM / -40°C
		Y = F	0-100 PPM / -20°C
Carbon Monoxide	(91)	Y = M	0-100 PPM / -20°C
		Y = N	0-100 PPM / -40°C
Chlorine	(97)	Y = A	
Chlorine Dioxide	(94)	Y = A	
Ethylene Oxide	(89)	Y = A	
Fluorine	(79)	Y = A	
Hydrogen	(87)	Y = A	0-4% Vol.
		Y = B	0-1% Vol.
Hydrogen Chloride	(84)	Y = A	

Gas	XX	Sensor Type (Y)	Notes
Hydrogen Cyanide	(99)	Y = A	
Hydrogen Fluoride	(72)	Y = A	
Hydrogen Sulfide	(82)	Y = A	
Mercaptan	(93)	Y = A	
Nitrogen Dioxide	(98)	Y = C	
Nitric Oxide	(83)	Y = A	
Oxygen	(70)	Y = D	0-25% Vol
Ozone	(88)	Y = A	
Phosgene	(77)	Y = A	
Phosphene	(76)	Y = A	
Sulphur Dioxide	(95)	Y = A	

Integral sensor (PVC) AMC 2XXAY1	Remote sensor (PVC) AMC 2XXBY1	Explosion proof	Explosion proof versions	
			AMC 2XXCY8	Class I, Div I, Group B, C, D
			AMC 2XXCY4	Class I, Div I, Group A, B, C, D
			AMC 2XXCY9	Class I, Div I, Group B, C, D corrosion resistant
Replacement sensor AMC XXAY	Replacement sensor AMC XXBY	Replacement sensor AMC XXCY	AMC 2XXCY6	Class I, Div I, Group A, B, C, D corrosion resistant
Replacement transmitter AMC 2XXAY0-T	Replacement transmitter AMC 2XXBY0-T	Replacement transmitter AMC 2XXCY0-T		



**AMC-210 WIRING DIAGRAMS**

**Integral Sensor Versions (A Style)**

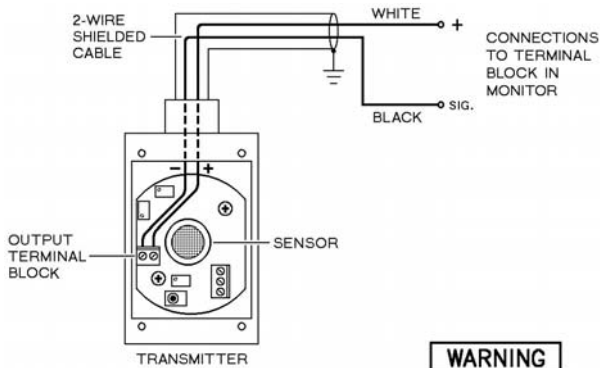

**WARNING**

CABLE SHIELD MUST NOT BE USED AS A CONDUCTOR.

**Remote Sensor Versions (B or C Style)**

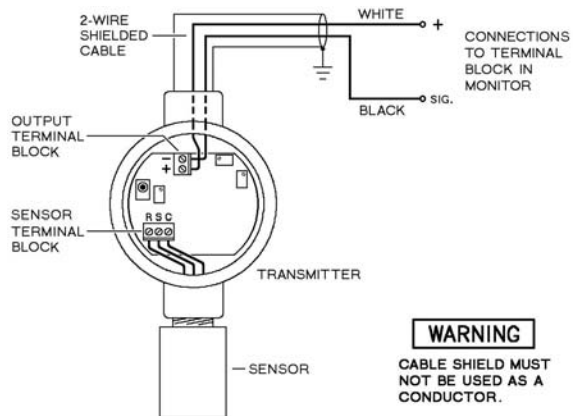

**WARNING**

CABLE SHIELD MUST NOT BE USED AS A CONDUCTOR.

**Integral Sensor Version to Non-AMC System**

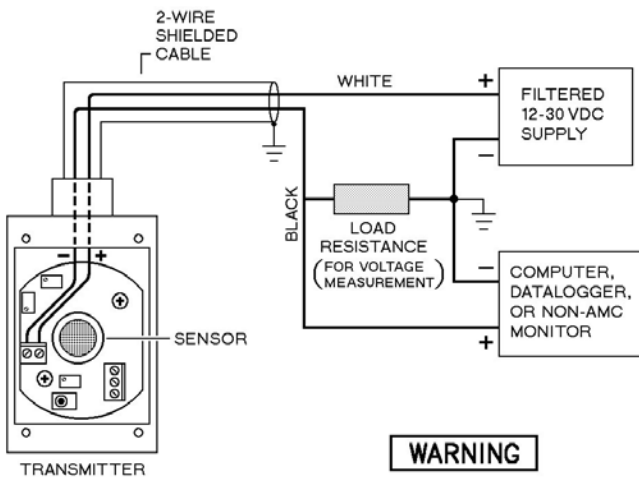

**WARNING**

CABLE SHIELD MUST NOT BE USED AS A CONDUCTOR.

**Remote Sensor Version to Non-AMC System**

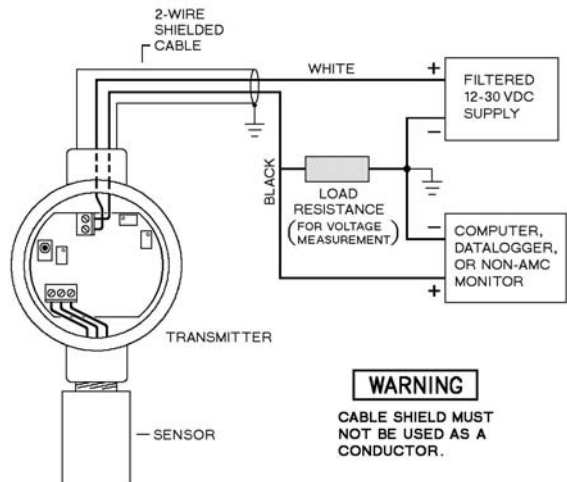

**WARNING**

CABLE SHIELD MUST NOT BE USED AS A CONDUCTOR.

