



1224/1225 Sensor Modules

INSTRUCTIONS

Installation and Operation of the
AMC-1224, 1225 Sensor Modules For Use With
AMC-1022D Monitors

IMPORTANT:

Please read these installation and operating instructions completely and carefully before starting.

filename: Manual_amc1224_1225.doc

Revised, 7/19/2004
Copyright ©, May 2001, AMC

The Armstrong Monitoring Corporation
215 Colonnade Road South, Nepean, Ontario, Canada K2E 7K3
Tel: (613) 225-9531 • Fax: (613) 225-6965 • U.S. & CANADA Toll Free: (800) 465-5777
E-mail: gas@armstrongmonitoring.com • Internet: www.armstrongmonitoring.com/gas/



TABLE OF CONTENTS

Section Title	Page
1 WARRANTY	3
1.1 LIABILITY	3
1.2 MODIFICATIONS AND SUBSTITUTIONS.....	3
1.3 PRODUCT RETURN.....	3
2 PRODUCT INFORMATION	4
2.1 AMC-1224, 1225 SENSOR MODULES	4
2.2 FACTORY CALIBRATION	4
3 PRODUCT DESCRIPTION	5
3.1 GENERAL DESCRIPTION	5
3.1.1 INTERNAL FEATURES	5
4 INSTALLATION	7
4.1 LOCATION AND MOUNTING	7
4.2 CABLE SELECTION AND WIRING	7
4.2.1 MULTI-UNIT INTERCONNECTION	7
4.2.2 TERMINATION.....	8
5 OPERATION AND CALIBRATION	10
5.1 OPERATION	10
5.1.1 ALARM CONDITIONS	10
5.1.2 FAULT SUPERVISION	10
5.2 CALIBRATION.....	10
5.2.1 SETTING UP CHAMBER AND APPLYING GAS.....	10
5.2.2 ADJUSTMENTS.....	11
6 MAINTENANCE	13
6.1 GENERAL	13
6.2 VERIFICATION OF OPERATION	13
6.3 SENSOR REPLACEMENT	13





1 WARRANTY

The AMC-1224, 1225 Modules are warranted against defects in material and workmanship for a period of one (1) year from date of delivery. During the warranty period, The Armstrong Monitoring Corporation will repair or replace components that prove to be defective in the opinion of AMC. We are not liable for auxiliary interfaced equipment, or consequential damage. This warranty shall not apply to any product, which has been modified in any way, which has been repaired by any other party other than a qualified technician or authorized AMC representative, or when such failure is due to misuse or conditions of use.

1.1 LIABILITY

All AMC products must be installed and maintained according to instructions. Only qualified technicians should install and maintain the equipment. AMC shall have no liability arising from auxiliary interfaced equipment, for consequential damage, or the installation and operation of this equipment. AMC shall have no liability for labour or freight costs, or any other costs or charges in excess of the amount of the invoice for the products.

THIS WARRANTY IS IN LIEU OF ALL OTHER WARRANTIES, EXPRESSED OR IMPLIED, AND SPECIFICALLY THE WARRANTIES OF MERCHANTABILITY AND FITNESS FOR A PARTICULAR PURPOSE. THERE ARE NO WARRANTIES THAT EXTEND BEYOND THE DESCRIPTION ON THE FACE THEREOF.

1.2 MODIFICATIONS AND SUBSTITUTIONS

Due to an ongoing development program, AMC reserves the right to substitute components and change specifications at any time without incurring any obligations.

1.3 PRODUCT RETURN

All products returned for warranty service will be by prepaid freight and they will only be accepted with a repair number issued by AMC. All products returned to the client will be freight collect.

WARNING

USING ELECTRICALLY OPERATED EQUIPMENT NEAR GASOLINE, OR GASOLINE VAPOURS MAY RESULT IN FIRE OR EXPLOSION, CAUSING PERSONAL INJURY AND PROPERTY DAMAGE. CHECK TO ASSURE THE WORKING AREA IS FREE FROM SUCH HAZARDS, AND USE PROPER PRECAUTIONS.



2 PRODUCT INFORMATION

2.1 AMC-1224, 1225 SENSOR MODULES

Sensor Module Part Number	_____
Sensor Module Serial Number	_____
Sensor Element Part Number.....	_____
Sensor Element Serial Number	_____
Wire Gauge	18 AWG @ 150 ft max between units
Power Supply Requirement	6 to 30 VDC
Operating Temperature	0 to 40 C
Operating Pressure	Ambient atmospheric pressure
Humidity	0 to 99% RH, non-condensing

2.2 FACTORY CALIBRATION

Gas type	_____
Low Alarm Setting	_____
High Alarm Setting	_____
Calibration Mixing Chamber Part Number.....	_____

Note:

All Armstrong Monitoring systems must be installed and maintained according to instructions, to ensure proper operation. Only qualified technicians should install and maintain the equipment.



3 PRODUCT DESCRIPTION

In this section a general product description is given followed by a detailed list of the AMC-1224, 1225 unit's internal features.

3.1 GENERAL DESCRIPTION

The AMC-1224, 1225 sensor unit provides continuous, reliable surveillance of surrounding air for traces of hazardous gases that are listed in the Product Information Section. This unit is designed to allow interconnection in series as in a "daisy chain" configuration (refer to Figure 2) to a single or multi-channel AMC-1022D series monitor or so equipped inputs of other AMC monitors. A maximum of eight (8) sensors can be connected to each zone. The units can also be branched out from the central line allowing maximum flexibility. Each unit provides Low alarm, High alarm and sensor Fail signals, which are transferred from one sensor to the next down the line back to the monitor.

3.1.1 INTERNAL FEATURES

Each sensor module features alarm indicators, adjustment trimmers and connection terminal blocks as listed and described below.

- 1) SENSOR: Long life solid state, no maintenance, factory calibrated
- 2) HIGH ALARM INDICATOR: High levels of gas are indicated by an illuminated red LED.
- 3) LOW ALARM INDICATOR: Low levels of gas are indicated by an illuminated yellow LED.
- 4) POWER / FAIL INDICATOR: Power is indicated by an illuminated green LED. A sensor failure causes the green LED to turn OFF.
- 5) HIGH ALARM ADJUSTMENT: Sets the high alarm trip point.
- 6) LOW ALARM ADJUSTMENT: Sets the low alarm trip point.
- 7) SIGNAL ADJUSTMENT: Sets the sensitivity of the sensor.
- 8) TERMINATING JUMPERS: Jumper clips are supplied installed on the circuit card. When connecting additional sensor modules, the jumper clip corresponding to the terminal block must be removed. Refer to section 4.2.2 TERMINATION for more details.
- 9) OUTPUT TERMINAL BLOCK: The output terminal block, labeled (-,s,+), connect to the (-,s,+) terminals in the monitor, or to the input (-,s,+) terminals of another sensor module.
- 10) INPUT TERMINAL BLOCKS: The input terminal blocks, labeled (-,s,+), are used to connect additional sensor modules. Each unused input terminal block must be locked-out using a terminal jumper, see Figure 1 – JP1, JP2.

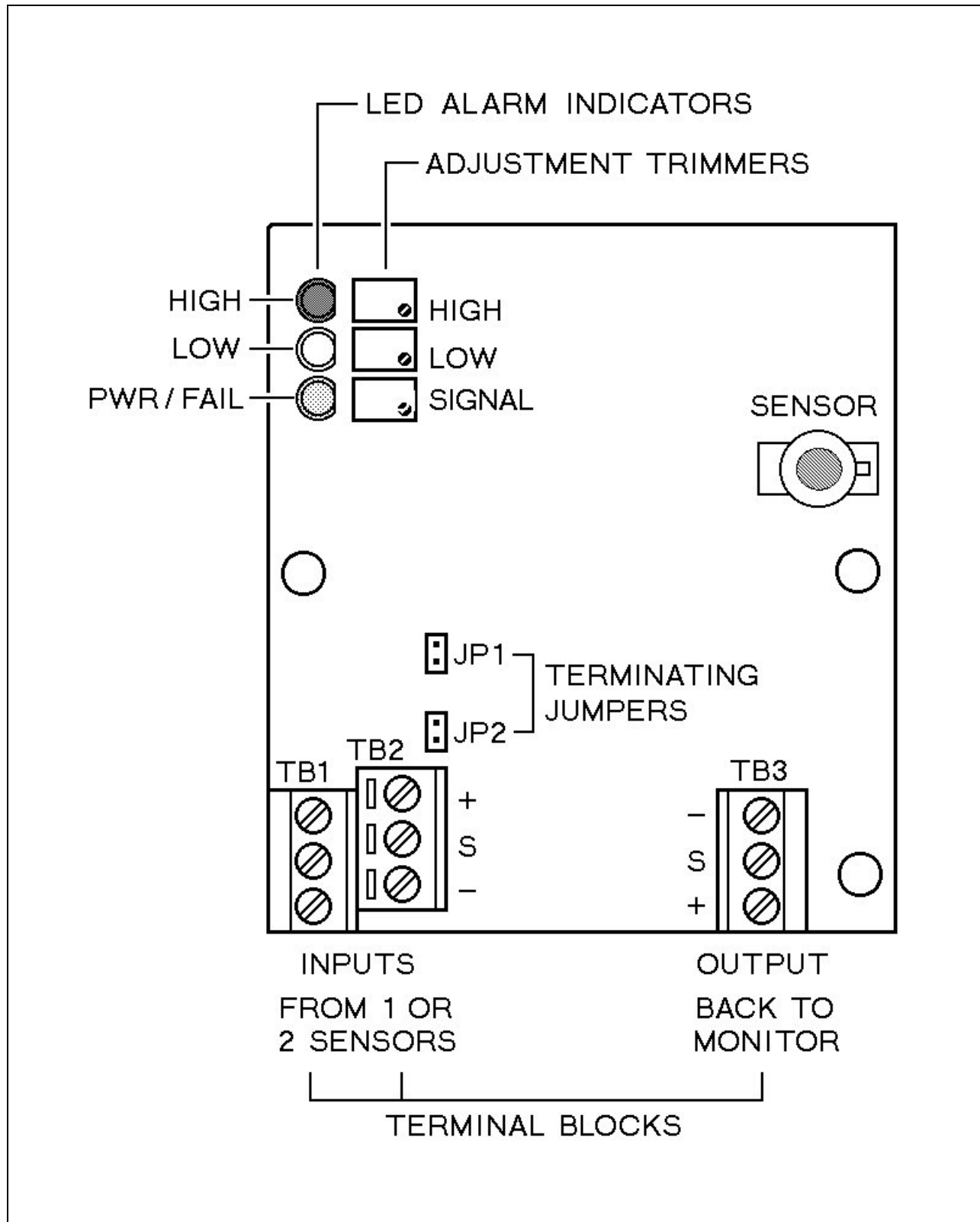

FIGURE 1: Internal Features of the AMC-1224, 1225 sensor module



4 INSTALLATION

This section discusses topics relating to the proper installation of the AMC-1224, 1225 unit. The proper location, sensor wiring selection and multi-unit interconnection are all discussed in detail in the following section.

4.1 LOCATION AND MOUNTING

Mount the sensor unit on a solid non-vibrating surface or structure easily accessible for status checking and calibration. The unit must be mounted in an area where the local concentration of gas is unaffected by the presence of ventilation systems.

NOTE:

**Mounting arrangement of the housing depends on location and mounting surface.
Mounting hardware is NOT supplied.**

4.2 CABLE SELECTION AND WIRING

To gain access to the terminal blocks, remove the four (4) screws and front panel from the housing. This will expose the field wiring terminals. The sensor / transmitter output (-,s,+) terminal block connects to the input terminal block of the previous unit or to the sensor / transmitter terminal block in the monitor as shown in Figure 2.

NOTE:

Turn off the power supply before removing or replacing the sensor.

Connection should be made using 3 conductor shielded cable (shield must be grounded at the monitor). Run cable through steel conduit for best signal transmission and maximum noise rejection. A maximum length of 150 feet of 18 AWG braided wire is allowed between each unit as well as between the monitor and first units. For other distances or cable sizes consult with The Armstrong Monitoring Corporation.

4.2.1 MULTI-UNIT INTERCONNECTION

Each sensor is designed to interconnect to other units in series and/or parallel combinations. Various typical configurations are shown in Figure 3, illustrating the versatility of this type of system. Because each sensor is pre-calibrated, additional units can be added to a system without altering the monitor settings. When multiple units are interconnected, either some or all jumpers need to be removed. See Figure 2.

4.2.2 TERMINATION

For any unused terminals a jumper has to be inserted. See Figure 2. Failure to do so may cause the system to malfunction.

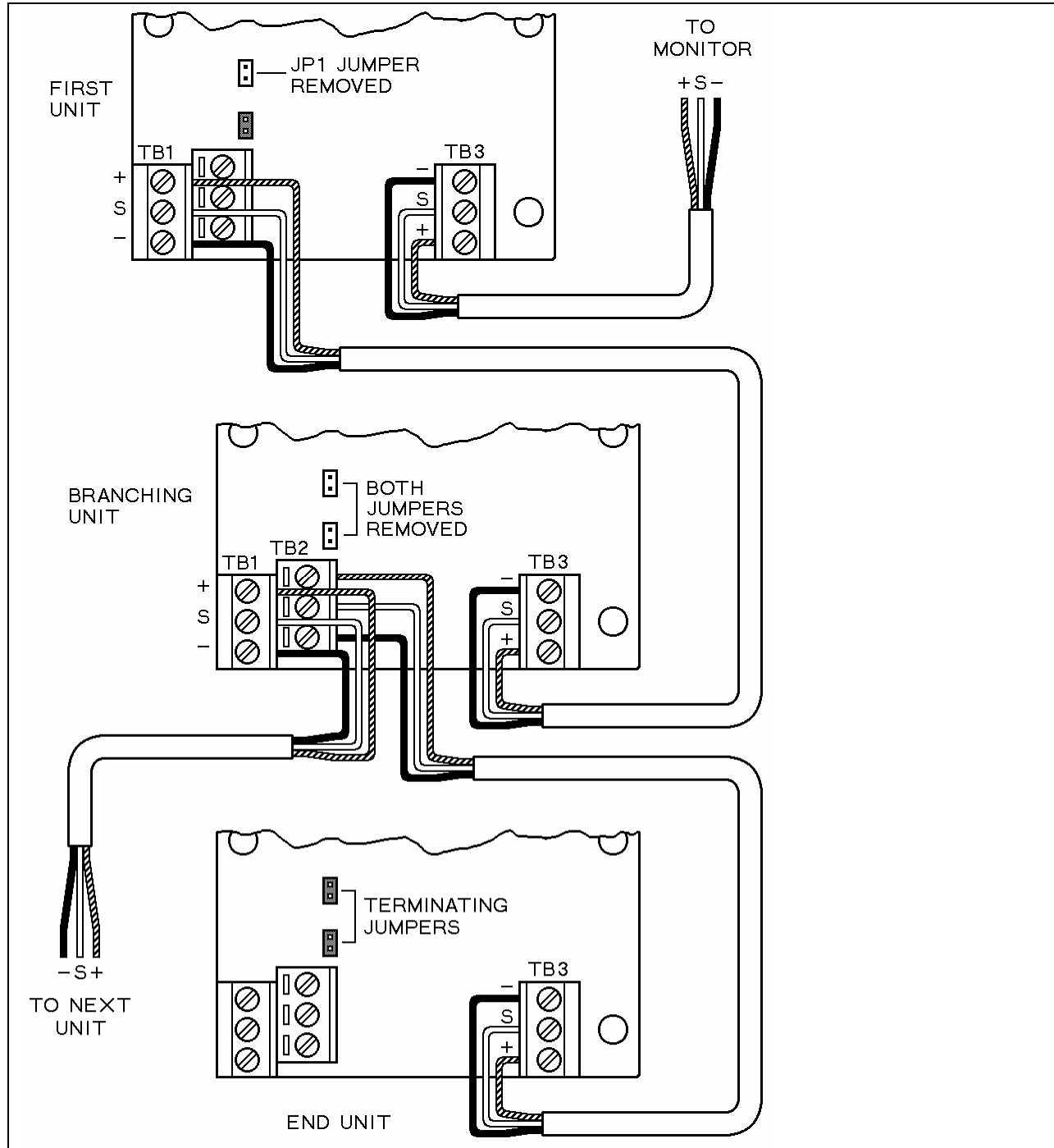

Figure 2 - Detail wiring of sensor modules

TYPICAL SYSTEM CONFIGURATIONS FOR ONE MONITOR AND 8 SENSORS.

LEGEND:

M = MONITOR

S = SENSOR MODULE

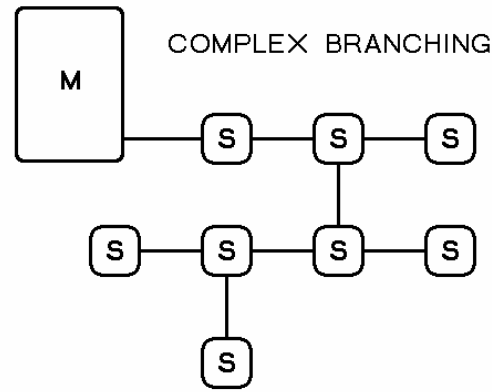
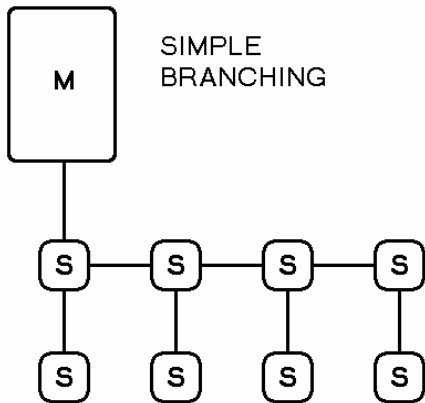
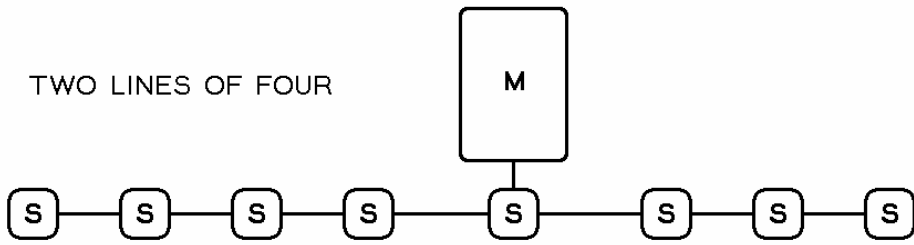
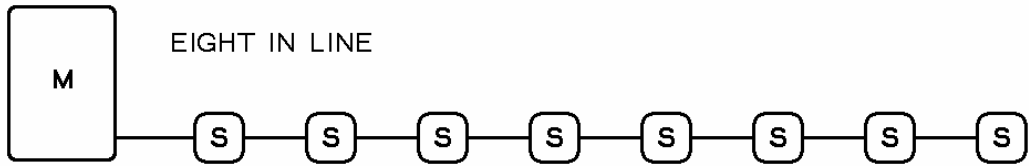
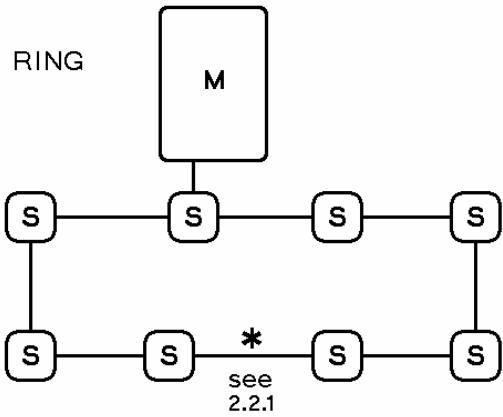

Figure 3 – Typical system configuration layouts



5 OPERATION AND CALIBRATION

This section covers instructions for the proper operation and calibration of the AMC-1224, 1225 unit. The operation principles are described in further detail followed by different types of periodic adjustments that might be required throughout the lifetime of the equipment.

5.1 OPERATION

In general, after the stabilization period and in a clean air environment, the sensor module should be displaying a GREEN Power ON LED. This green indicator, as well as the yellow and red alarm indicators, are all visible through windows on the front panel.

5.1.1 ALARM CONDITIONS

If any gas exceeds the LOW alarm trip point setting, the yellow LED will turn ON and the unit will transmit a signal and turn ON the yellow LED at the monitor. Likewise, if any gas exceeds the HIGH alarm trip point setting, the red LED will turn ON.

5.1.2 FAULT SUPERVISION

The AMC-1224, 1225 is equipped with fault detection circuitry. This condition is indicated by turning OFF the green LED viewed through the front panel. The condition will exist until the fault is corrected.

5.2 CALIBRATION

The AMC-1224, 1225 sensor unit is factory calibrated at levels based on set standards. Calibration of the unit should last for the life of the sensor, with few periodic adjustments, unless the alarm trip point settings need to be changed. All on site adjustments are made at each transmitter.

Recalibration is necessary when replacing the sensor or changing the alarm trip point settings. Use Armstrong's calibration mixing chamber, refer to section 2.2 FACTORY CALIBRATION for proper part number. Factory or on site calibration services and customer training can be provided. Specify the sensor / transmitter model number and gas when requesting any of the above.

5.2.1 SETTING UP CHAMBER AND APPLYING GAS

To set up the calibration chamber, prior to applying gas to the sensor, follow the diagram shown in Figure 4. Once the chamber is set up, a gas sample can be taken and injected into the chamber for calibration. Measure gas with the appropriate syringe (1 cc or 5 CC) to obtain the desired concentration of gas being detected. Refer to the instructions and chart in the AMC-CK2700 calibration mixing chamber manual.



5.2.2 ADJUSTMENTS

All calibration adjustments are made using the three trimmers next to the single row of LEDs, see Figure 1.

The LOW alarm adjustment is used to establish the low alarm trip point. This is done by exposing the sensor to a low alarm gas concentration and adjusting the LOW trimmer counterclockwise until the YELLOW LED just lights up.

The HIGH alarm adjustment is used to establish the high alarm trip point. This is done by exposing the sensor to a high alarm gas concentration and adjusting the HIGH trimmer counterclockwise until the RED LED just lights up.

NOTE:

If the sensor has been replaced, adjust the SIGNAL first, then proceed with LOW alarm and HIGH alarm adjustments. Signal calibration is performed using a digital multimeter set to measure DC voltages to two (2) decimal places (e.g. 0.00 Volts).

The SIGNAL adjust is used to set the sensitivity of the sensor. This is done by exposing the sensor to the LOW alarm concentration of gas. The voltage associated with signal can be measured between the negative (-) power line on the output terminal block and the test point next to the signal trimmer, see Figure 4. The voltage measured at the signal test point should be approximately 1.20 Volts.

When calibration is completed, remove the calibration chamber, replace the sensor element while observing the correct polarity, and then reinstall the cover plate with the four screws.

CAUTION:

Only qualified personnel should perform the actual calibration. Users are advised to consult The Armstrong Monitoring Corporation as to the recommended calibration gas concentration for the application, and any other questions.

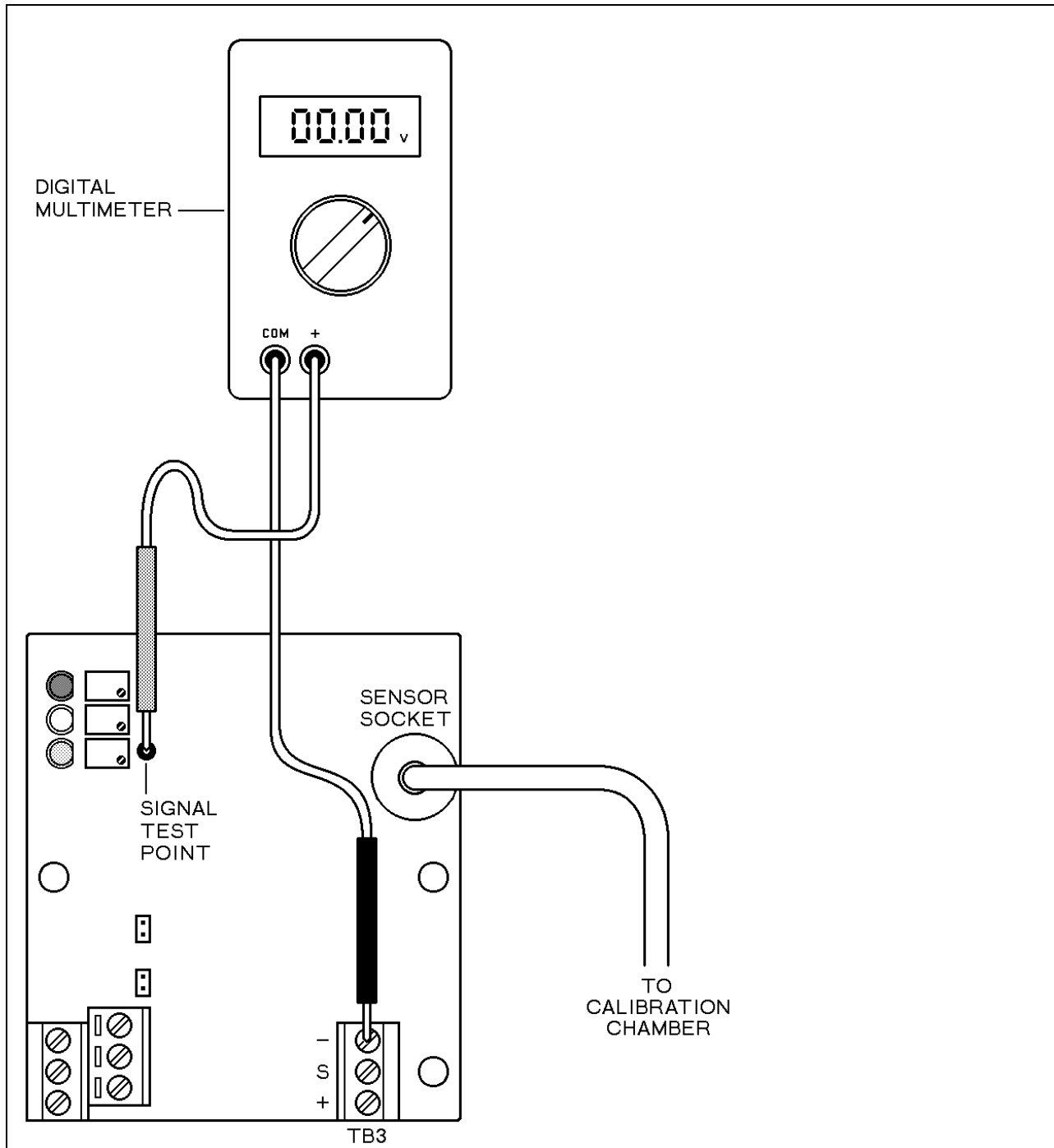

Figure 4 – Calibration / Verification set-up procedure



6 MAINTENANCE

This section covers topics related to the maintenance of the AMC-1224, 1225 unit. A general description of maintenance to be carried out is followed by a verification of operation and then details about the sensor replacement.

6.1 GENERAL

The sensor unit should be brushed or wiped clean once a year or more of any dust or dirt which settles on it depending on the accumulation.

The unit should NOT be submerged or placed under conditions where water or other liquids would be able to enter the transmitter.

6.2 VERIFICATION OF OPERATION

Verification of operation should be done at least once every 6 months for safety reasons and for highly demanding applications monthly verification is recommended.

6.3 SENSOR REPLACEMENT

Sensor life is typically in excess of 10 years. The sensor should be replaced when the green LED turns OFF while the unit is powered.

CAUTION:

Turn off the power supply before attempting the following.

When the sensor needs replacing, reorder the Part Number listed in Product Information (page 4). To replace the sensor element remove the four screws and cover plate from the housing. Unplug the used sensor element from its socket and discard. Then plug in the replacement sensor element. Reinstall the cover plate and screws.

NOTE:

Allow 24 hours for the new sensor element to stabilize (burn-in) before recalibration, then follow instructions in the Calibration section of this manual.