

1222

CO/NO₂ Multidrop

INSTRUCTIONS

Installation and Operation of the
AMC-1222 Dual Electrochemical Sensor
Module with Comfort Zone

IMPORTANT:

Please read these installation and operating instructions completely and carefully before starting.

File name:3571405A

Copyright ©, Aug 2018

The Armstrong Monitoring Corporation
215 Colonnade Road South, Ottawa, Ontario, Canada K2E 7K3
Tel: (613) 225-9531 • Fax: (613) 225-6965 • Canada & U.S. Toll Free: (800) 465-5777
E-mail: gas@armstrongmonitoring.com • Internet: www.armstrongmonitoring.com



TABLE OF CONTENTS

Section Title	Page
1 WARRANTY	3
1.1 LIABILITY	3
1.2 MODIFICATIONS AND SUBSTITUTIONS.....	3
1.3 PRODUCT RETURN.....	3
2 PRODUCT INFORMATION	4
2.1 Sensor module	5
2.2 Factory Calibration AMC1222 1/ 2 variants.....	5
2.3 Factory Calibration AMC-1222-3	6
3 PRODUCT DESCRIPTION	7
3.1 GENERAL DESCRIPTION.....	7
3.1.1 Internal Features	7
4 INSTALLATION	10
4.1 LOCATION AND MOUNTING	10
4.2 CABLE SELECTION AND WIRING	13
4.2.1 Multi-Unit Interconnection.....	13
4.2.2 TERMINATION.....	13
5 OPERATION AND CALIBRATION	15
5.1 OPERATION	15
5.1.1 LOW AND HIGH ALARM CONDITIONS.....	15
5.1.2 COMFORT ZONE	15
5.2 CALIBRATION.....	16
5.2.1 Zero Adjustment (CO)	16
5.2.2 Span Adjustment for (CO) 100 PPM (AMC1222-1 and -2 variants).....	16
5.2.3 Span Adjustment for (CO) 75 PPM (AMC-1222-3)	17
5.2.4 Zero Adjustment (NO ₂)	18
5.2.5 Span Adjustment (NO ₂).....	18
MAINTENANCE	20
5.3 GENERAL	20
5.4 VERIFICATION OF OPERATION	20
5.5 SENSOR REPLACEMENT	20
Figure 2-1 AMC-1222 Sensor Module	4
Figure 3-1 Internal Features of the AMC-1222 Sensor Module	9
Figure 4-1 Transmitter Mounting Dimensions.....	11
Figure 4-2 Pole Mount	12
Figure 4-3 Detail wiring of Sensor Modules	14
Figure 4-4 Typical System Configuration Layout.....	14
Figure 5-1 Calibration Procedure for 1222 CO	17
Figure 5-2 Calibration Procedure for 1222 NO ₂	19



NOTE

This page intentionally left blank



1 WARRANTY

The AMC-1222 Module is warranted against defects in material and workmanship for a period of two years from date of shipment (For sensor warranties see section 2.1). During the warranty period, The Armstrong Monitoring Corporation will repair or replace components that prove to be defective in the opinion of AMC. We are not liable for auxiliary interfaced equipment, or consequential damage. This warranty shall not apply to any product, which has been modified in any way, which has been repaired by any other party other than a qualified technician or authorized AMC representative, or when such failure is due to misuse or conditions of use.

1.1 LIABILITY

All AMC products must be installed and maintained according to instructions. Only qualified technicians should install and maintain the equipment. AMC shall have no liability arising from auxiliary interfaced equipment, for consequential damage, or the installation and operation of this equipment. AMC shall have no liability for labour or freight costs, or any other costs or charges in excess of the amount of the invoice for the products.

THIS WARRANTY IS IN LIEU OF ALL OTHER WARRANTIES, EXPRESSED OR IMPLIED, AND SPECIFICALLY THE WARRANTIES OF MERCHANTABILITY AND FITNESS FOR A PARTICULAR PURPOSE. THERE ARE NO WARRANTIES THAT EXTEND BEYOND THE DESCRIPTION ON THE FACE THEREOF.

1.2 MODIFICATIONS AND SUBSTITUTIONS

Due to an ongoing development program, AMC reserves the right to substitute components and change specifications at any time without incurring any obligations.

1.3 PRODUCT RETURN

All products returned for warranty service will be by prepaid freight and they will only be accepted with a repair number issued by AMC. All products returned to the client will be freight collect.

WARNING

<p>USING ELECTRICALLY OPERATED EQUIPMENT NEAR GASOLINE, OR GASOLINE VAPOURS MAY RESULT IN FIRE OR EXPLOSION, CAUSING PERSONAL INJURY AND PROPERTY DAMAGE. CHECK TO ASSURE THE WORKING AREA IS FREE FROM SUCH HAZARDS DURING INSTALLATION OR WHEN PERFORMING MAINTENANCE, AND USE PROPER PRECAUTIONS.</p>

2 PRODUCT INFORMATION



Figure 2-1 AMC-1222 Sensor Module



2.1 Sensor module

Sensor Module Part Number	AMC 1222
Sensor Module Serial Number	
CO Sensor Element Part Number	AMC 91A
CO Sensor Element Serial Number	
CO Sensor Element Warranty Period	year(s)
NO ₂ Sensor Element Part Number	AMC 98A
NO ₂ Sensor Element Serial Number	
NO ₂ Sensor Element Warranty Period	year(s)
Power Supply Requirement	12 to 24 VDC
Operating Temperature	-20° to 40° C
Operating Pressure	Ambient atmospheric pressure
Relative Humidity	10 to 95% RH, non-condensing

2.2 Factory Calibration AMC1222 1/ 2 variants

Gas Type	CO	NO ₂
Low Alarm Setting	25 ppm or 35ppm *	1 ppm
High Alarm Setting / Full Scale.....	100 ppm	3 ppm
Comfort Zone Alarm	User Selectable Sensitivity	User Selectable Sensitivity
Calibration Adapter Part Number.....	N/A	N/A

* Variant AMC1222-1 is configured for 35ppm CO Low Alarm Setting, AMC1222-2 is configured for 25ppm CO Low Alarm Setting.



2.3 Factory Calibration AMC-1222-3

Gas Type	CO	NO ₂
Low Alarm Setting	25 ppm	1 ppm
High Alarm Setting / Full Scale.....	75 ppm	3 ppm
Comfort Zone Alarm	User Selectable Sensitivity	User Selectable Sensitivity
Calibration Adapter Part Number.....	N/A	N/A

* Variant AMC1222-3 is configured for 25ppm CO Low Alarm Setting and 75ppm CO High Alarm Setting.

Note:

All Armstrong Monitoring systems must be installed and maintained according to instructions, to ensure proper operation. Only qualified technicians should install and maintain the equipment. Qualified personnel should perform the installation according to applicable electrical codes, regulations and safety standards. Insure correct cabling practices are implemented.



3 PRODUCT DESCRIPTION

In this section a general product description is given followed by a detailed list of the AMC-1222 module's internal features.

3.1 GENERAL DESCRIPTION

The AMC-1222 sensor module provides continuous, reliable surveillance of surrounding air for traces of hazardous gases (listed in section 2.2 FACTORY CALIBRATION, page 4). This module is designed to allow interconnection in series as in a "daisy chain" configuration (refer to Figure 4-3) to a single or multi-zone AMC 1AD Series monitor or to any other monitor which can accept voltage or current signal as specified in section 5.1 OPERATION. When using an AMC 1AD Series monitor, a maximum of eight (8) sensor modules can be connected to each zone. Each module produces Low alarm, High alarm and Fail signals, which are transferred from one sensor module up the line of modules to the monitor.

3.1.1 INTERNAL FEATURES

Each sensor module features alarm indicators, adjustment trimmers and connection terminal blocks, as listed and described below.

- | | |
|----------------------------------------------|--------------------------------------------------------------------------------------------------------------------------------------------------------------------------------------------------------------------------------------|
| 1. CO SENSOR: | Electrochemical cell, factory calibrated. |
| 2. NO ₂ SENSOR: | Electrochemical cell, factory calibrated. |
| 3. CO LOW/HIGH ALARM INDICATOR: | Low conditions of CO gas are indicated by a red blinking LED and High conditions are indicated by a solid red LED. |
| 4. NO ₂ LOW/HIGH ALARM INDICATOR: | Low conditions of NO ₂ gas are indicated by a red blinking LED and High conditions are indicated by a solid red LED. |
| 5. COMFORT ZONE ALARM INDICATOR: | Comfort Zone condition is indicated by an amber LED. |
| 6. POWER/FAIL INDICATOR: | Power is indicated by an illuminated green LED. Fail indicated by flashing LED. |
| 7. EIGHT POSITION DIP SWITCH: | Each actuator on the DIP switch controls a different circuit as shown in Figure 3-1. If the actuator is set in the RIGHT position, its corresponding circuit is ON. If the actuator is set in the LEFT position, the circuit is OFF. |
| 7-1 EOL (end of line) DIP SWITCH: | The EOL is switched on for the last module in a chain and is off for all others. Refer to section 4.2.2 TERMINATION, for more details. |
| 7-2 Comfort Zone DIP SWITCH | This Switch is used to enable (ON) or Disable (OFF) the comfort zone alarm feature. Default setting for this switch is OFF |



7-3 TD DIP SWITCH:	5 minute alarm output activation time delay for CO sensor only.
7-4 MR DIP SWITCH:	Keeps the output signal on the last alarm level on for 5 minutes longer after the alarm condition has cleared
7-5 DIP SWITCH:	Dip switch positions used to set the comfort zone sensitivity. SW5(A) SW6(B) SW7(C) SW8(D) Sensitivity
7-6 A DIP SWITCHES:	OFF OFF OFF OFF Super High
7-7 B DIP SWITCHES:	OFF ON OFF ON High
7-8 C DIP SWITCHES:	ON OFF ON OFF Med
7-8 D DIP SWITCHES:	ON ON ON ON Low
8-A CO SPAN SIGNAL ADJUSTMENT:	Sets the sensitivity of the CO sensor.
8-B NO ₂ SPAN SIGNAL ADJUSTMENT:	Sets the sensitivity of the NO ₂ sensor.
8-C NO ₂ ZERO SIGNAL ADJUSTMENT:	Sets the zero NO ₂ signal.
8-D CO ZERO SIGNAL ADJUSTMENT:	Sets the zero CO signal.
9. INPUT	The input terminal block is used to connect additional sensor modules. If input terminal block is not used, EOL is switched ON
10. OUTPUT	The output terminal block connects to the monitor or the input terminal of another module.
11. CURRENT/VOLTAGE JUMPERS	Configure between current or voltage output. Jumpers on "I" for current output and on "V" for voltage output.
12. NO ₂ SPAN CALIBRATION JUMPER	Configure NO ₂ calibration gas concentration. Jumper on "A" for normal and on "B" for double gas concentration calibration.

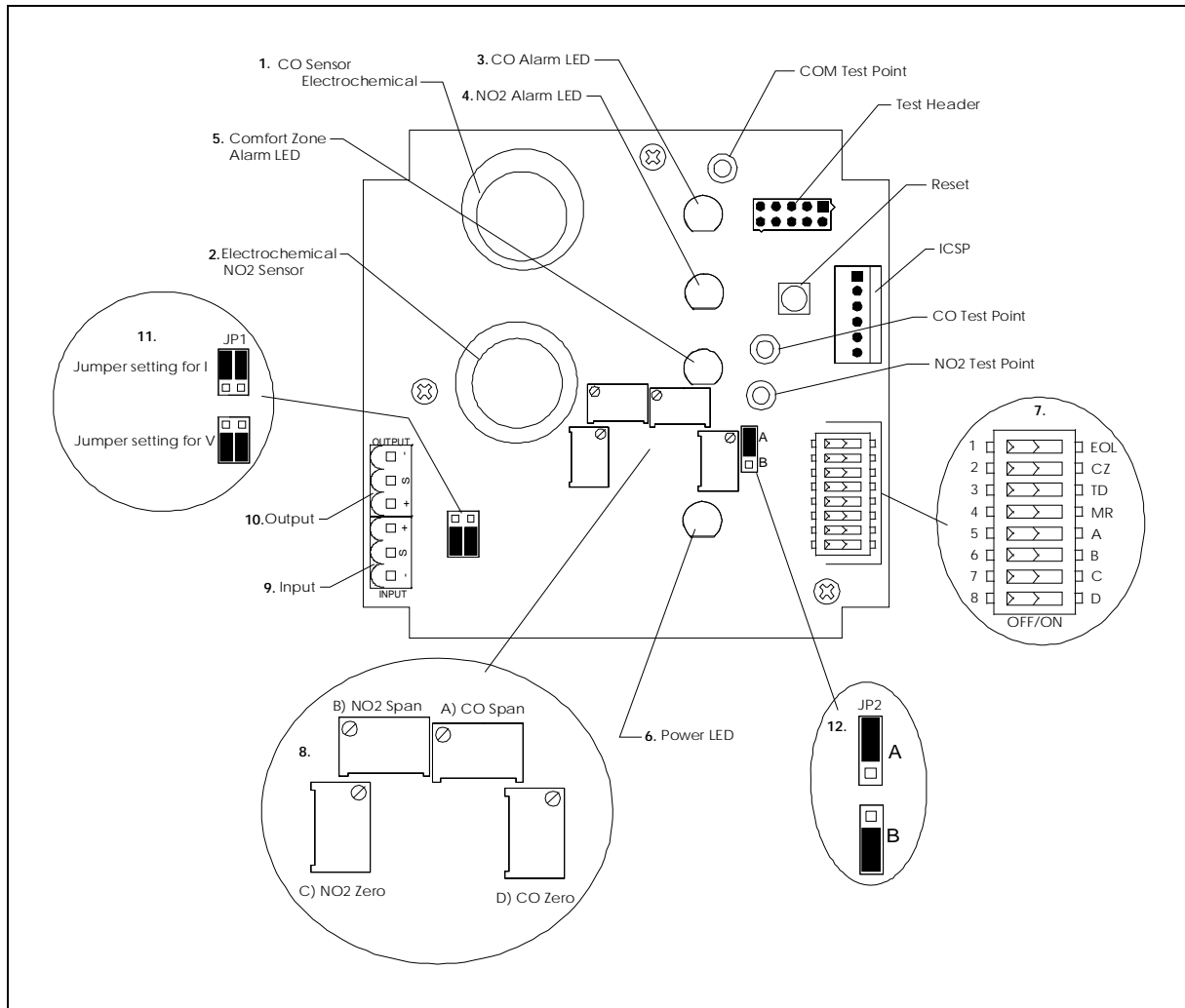

Figure 3-1 Internal Features of the AMC-1222 Sensor Module



4 INSTALLATION

This section relates to the proper installation of the AMC-1222 module. The topics of proper location, sensor wiring selection, and multi-unit interconnection are all discussed in detail.

4.1 LOCATION AND MOUNTING

Mount the sensor module on a solid, non-vibrating surface or structure, easily accessible for status checking and calibration. The module must be mounted in an area where the local concentration of gas is unaffected by the presence of ventilation systems. Mounting height of modules must be in compliance with local legislations and regulations.

4.1.1 MOUNTING

1. Remove cover and mounting bracket with transmitter.
2. Mount housing using defines mounting holes. See Figure 4-1 or Figure 4-2.
3. Drill holes for conduit and then install conduit. See Warning below.
4. Reattach cover and bracket.

Warning:

Conduit should enter the housing from the bottom to ensure best protection against ingress of condensation.

Conduit entry from the top from the top of the housing is Not Recommended, and will Void the Warranty. However, if conduit entry through the top is the only available option, a Condensation Drip Shield is provided to help protect the electronics from water ingress due to condensation from the EMT conduit. If conduit entry is through the top of the housing, a drain hole must be drilled into the bottom side of the housing to allow the condensation to exit the housing.

Note:

Mounting arrangement of the housing depends on the location and mounting surface. Mounting hardware is NOT supplied.



Figure 4-1 Transmitter Mounting Dimensions

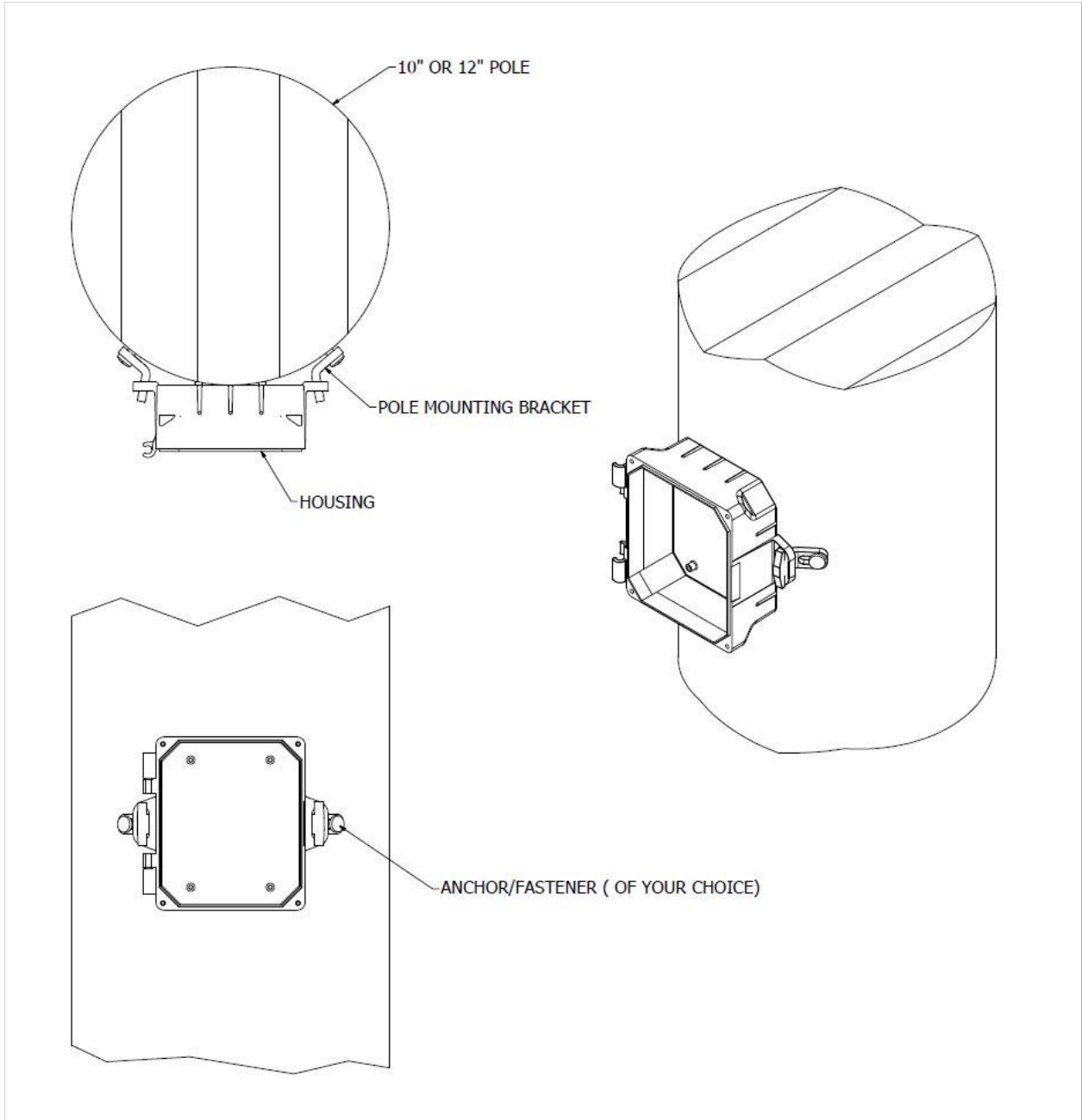

Figure 4-2 Pole Mount



4.2 CABLE SELECTION AND WIRING

To gain access to the terminal blocks, remove the four (4) screws and front panel from the housing. This will expose the field wiring terminals. The sensor module output (-,OUT,+) terminal block, connects to the input (-,IN,+) terminal block of the next module towards the monitor, or to the sensor/transmitter terminal block in the monitor, as shown in Figure 4-3.

Connection should be made using 3-conductor, shielded cable (shield must be grounded at the monitor). Run cable through steel conduit for best signal transmission and maximum noise rejection. When using an AMC 1AD Series monitor and with eight (8) modules, a maximum length of 150 feet of 18 AWG size cable is allowed between each module as well as between the monitor and first module. For other distances or cable sizes, consult with The Armstrong Monitoring Corporation.

4.2.1 MULTI-UNIT INTERCONNECTION

Each sensor module is designed to interconnect to other modules in series configuration. Typical configuration is shown in Figure 4-4. Since each module is pre-calibrated, additional modules can be added to a system without altering the monitor settings. When multiple modules are interconnected, the EOL switch is in the off position except for the last one (refer to section 4.2.2 TERMINATION and Figure 4-3).

4.2.2 TERMINATION

The input terminal block for the last module in the chain will be empty and the EOL (end of line) DIP switch is switched on.

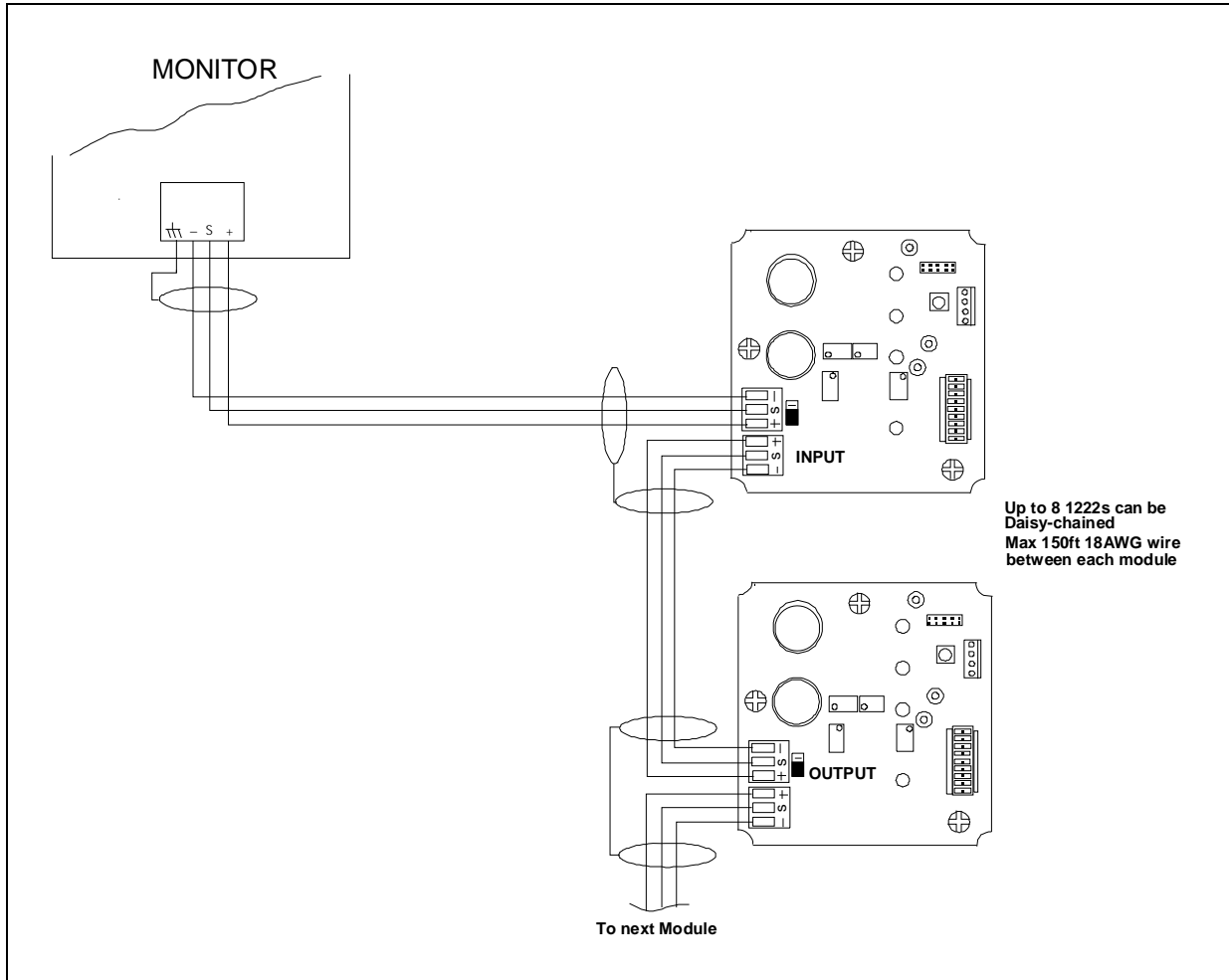

Figure 4-3 Detail wiring of Sensor Modules

TYPICAL SYSTEM CONFIGURATIONS FOR ONE MONITOR AND 8 SENSORS.

LEGEND:
M = MONITOR
S = SENSOR MODULE

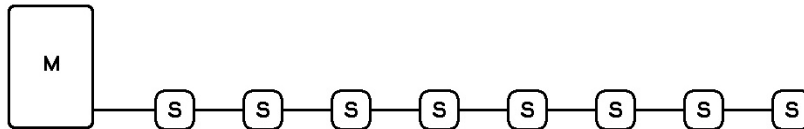

Figure 4-4 Typical System Configuration Layout



5 OPERATION AND CALIBRATION

This section covers instructions for the proper operation and calibration of the AMC-1222 module. The operation principles are described in further detail, followed by different types of periodic adjustments that might be required throughout the lifetime of the equipment.

5.1 OPERATION

In general, after the stabilization period and in a clean air environment, the sensor module should be displaying a GREEN Power ON LED. This green indicator, as well as the two red alarm indicators and the amber logic indicator, are all visible through windows on the front panel. Fail is indicated by a flashing power LED.

Input and Output Magnitudes in Various Conditions in Current or Voltage Mode:

Operation condition	Voltage Mode	Current Mode
Fail	0 VDC	0 mA
Normal	1 VDC	4 mA
Low Alarm	2 VDC	8 mA
High Alarm	3 VDC	12 mA

5.1.1 LOW AND HIGH ALARM CONDITIONS

If any gas exceeds the LOW alarm trip point setting, the red LED will start flashing and the module will transmit a Low Alarm signal, and when using an AMC 1AD Series monitor, it also turns ON the yellow LED at the monitor. Likewise, if any gas exceeds the HIGH alarm trip point setting, the red LED's will turn ON and transmit a High Alarm signal to the monitor.

5.1.2 COMFORT ZONE

The comfort zone alarm condition is user selectable by using four DIP switches; three switches for CO gas and one for NO₂ gas. When activated the amber LED turns ON and outputs to the monitor the same as the Low Alarm condition.

SW5(A)	SW6(B)	SW7(C)	SW8(D)	Sensitivity
OFF	OFF	OFF	OFF	Super High
OFF	ON	OFF	ON	High
ON	OFF	ON	OFF	Med
ON	ON	ON	ON	Low



5.2 CALIBRATION

The AMC-1222 sensor module is factory calibrated at levels based on set standards. Calibration of the module should last for the life of the sensor, with few periodic adjustments. All on-site adjustments are made at each sensor module. Recalibration is necessary when replacing the sensor. Factory or on-site calibration services, customer training, and/or calibration adapter can be provided. Specify each sensor module's model number and gas when requesting any of the above. Refer to sections 2.1 Sensor module and/or 2.2 FACTORY CALIBRATION for any of the above required information.

Notes:

- The calibration procedure is the same whether the module is in current or voltage mode. Voltage is measured at the test points when the module is in either mode.

Equipment Required:

- Digital Multimeter
- Miniature slot screw driver
- CO and NO₂ Calibration Adapters
- Zero & Span gases and regulator (Contact factory for information)

5.2.1 ZERO ADJUSTMENT (CO)

Step 1 Remove cover

Step 2 Power unit from 12-24VDC Supply, Ensure green power LED illuminates. If power LED is flashing ensure EOL (end of line) Switch(es) are set correctly.

Step 3 Set multimeter to DC voltage range suitable for reading 2.00VDC

Step 4 Connect Multimeter to COM(-) and TP2 as shown in Figure 5-1

Step 5 Apply Zero gas @ 1L/min

Step 6 After signal reading has stabilized (approx 1 min) adjust Zero Potentiometer to 0.00VDC

Step 7 Remove calibration gas

5.2.2 SPAN ADJUSTMENT FOR (CO) 100 PPM (AMC1222-1 AND -2 VARIANTS)

Step 8 Apply CO span gas, CO span gas concentration should be in 25ppm to 100ppm CO range

Step 9 After the signal reading has stabilized (approx 3 min) adjust Span potentiometer to $2.00\text{VDC}/100 \times \text{Span gas concentration}$. i.e. if using 50 ppm CO $2.00\text{VDC}/100 \times 50 = 1.00\text{VDC}$

Step 10 If Signal > .7VDC verify CO Alarm LED Flashes, If Signal > 2.00VDC verify CO Alarm LED Illuminates steady State

Step 11 Remove Gas, Calibration complete

5.2.3 SPAN ADJUSTMENT FOR (CO) 75 PPM (AMC-1222-3)

Step 8 Apply CO span gas, CO span gas concentration should be in 25ppm to 75ppm CO range

Step 9 After the signal reading has stabilized (approx 3 min) adjust Span potentiometer to $2.00\text{VDC}/75 \times \text{Span gas concentration}$. i.e. if using 25 ppm CO $2.00\text{VDC}/75 \times 25 = 0.6667\text{VDC}$

Step 10 If Signal > .7VDC verify CO Alarm LED Flashes, If Signal > 2.00VDC verify CO Alarm LED Illuminates steady State

Step 11 Remove Gas, Calibration complete

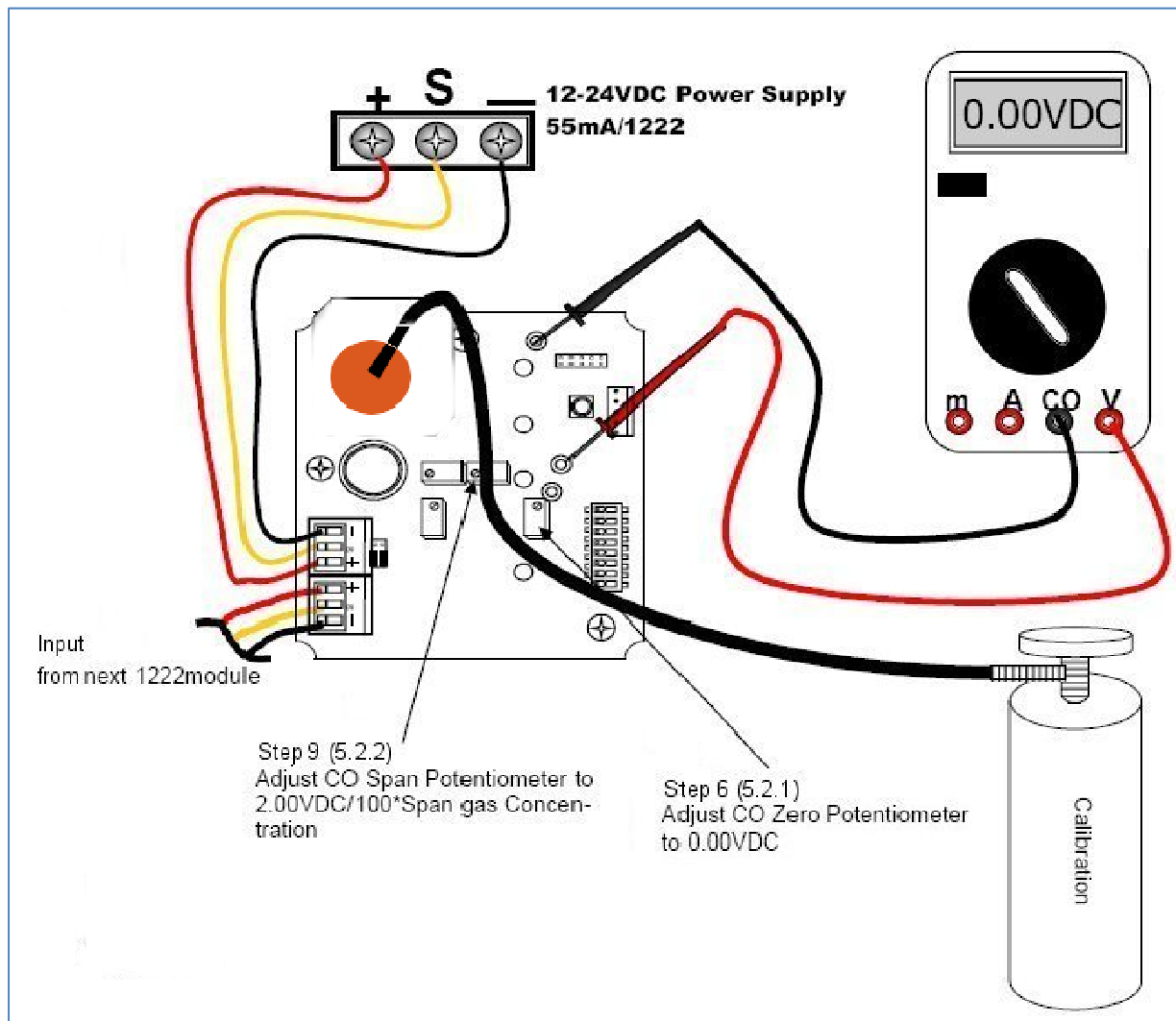

Figure 5-1 Calibration Procedure for 1222 CO



5.2.4 ZERO ADJUSTMENT (NO₂)

Step 1 Remove cover

Step 2 Power unit from 12-24VDC Supply, Ensure green power LED illuminates. If power LED is flashing ensure EOL (end of line) Switch(es) are set correctly.

Step 3 Set multimeter to DC voltage range suitable for reading 2.00VDC

Step 4 Connect Multimeter to COM(-) and TP1 as shown in Figure 5-2

Step 5 Apply Zero gas @ 1L/min

Step 6 After signal reading has stabilized (approx 1 min) adjust Zero Potentiometer to 0.00VDC

Step 7 Remove calibration gas

5.2.5 SPAN ADJUSTMENT (NO₂)

There are two possible calibration modes; A and B. They are selectable using NO₂ span calibration jumper, JP2, see section 3.1.1 item 12. Mode A is normal mode. Mode B allows the AMC 1222 to measure only half of the calibration gas. This is useful as 2.5 or 3ppm calibration gas is not common to purchase but 5 or 6ppm is.

Step 8 Using Teflon hose apply NO₂ span gas, NO₂ Span gas concentration should be in 1ppm to 3ppm NO₂ range

Step 9 After the signal reading has stabilized (approx 3 min) adjust Span potentiometer to 2.00VDC/3*Span gas concentration. i.e. if using 1.5 ppm NO₂
 $2.00\text{VDC}/3*1.5=1.00\text{VDC}$

Note: If mode B calibration is use, divide span gas concentration by 2 before using the above calculation. i.e. if using 5ppm NO₂
 $2.00\text{VDC}/3*5/2=1.67\text{VDC}$

Step 10 If Signal > .66VDC verify NO₂ Alarm LED Flashes, If Signal > 2.00VDC verify NO₂ Alarm LED Illuminates steady State

Step 11 Remove Gas and unit must be in mode A for normal operation, Calibration complete

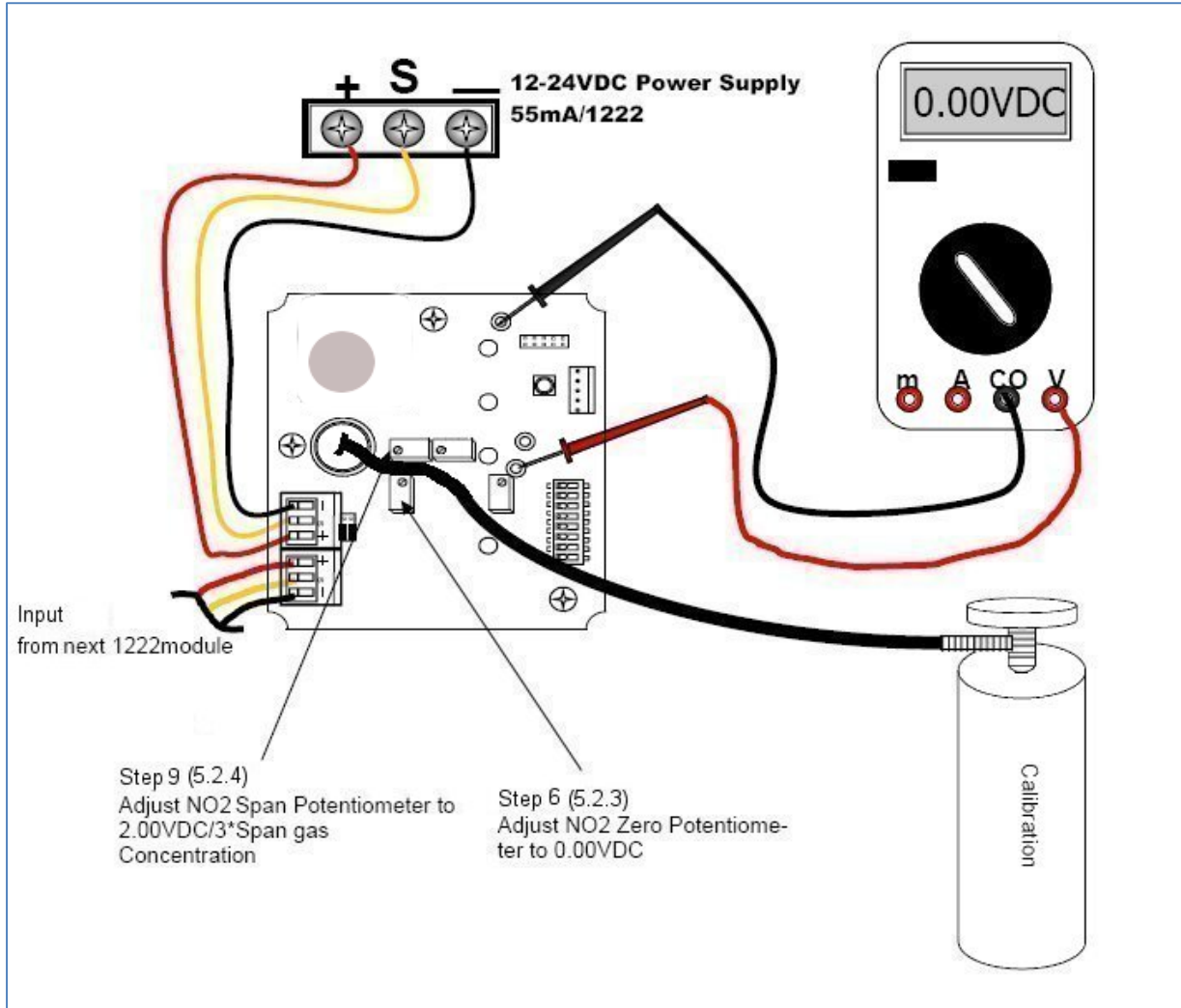

Figure 5-2 Calibration Procedure for 1222 NO₂



MAINTENANCE

This section covers topics related to the maintenance of the AMC-1222 module. A general description of maintenance to be carried out is followed by a verification of operation and then details about the sensor replacement.

5.3 GENERAL

The sensor module should be brushed or wiped clean once a year or more, of any dust or dirt which settles on it, depending on the accumulation. The module **SHOULD NOT** be submerged or placed under conditions where water or other liquids would be able to enter the transmitter.

5.4 VERIFICATION OF OPERATION

Verification of operation and calibration should be done at least once every 6 months for safety reasons and for highly demanding applications, monthly verification is recommended.

5.5 SENSOR REPLACEMENT

The sensor should be replaced when the sensor no longer adequately responds to test gas.

CAUTION:

Turn off the power supply before attempting the following.

When the sensor needs replacing, reorder the Part Number listed in section 2.1 SENSOR MODULE (page 4). To replace the sensor element, remove the four screws and cover plate from the housing. Unplug the used sensor element from its socket and discard then plug in the replacement sensor element. Reinstall the cover plate and screws.

Note:

Allow 24 hours for the new sensor element to stabilize (burn-in) before recalibrations then follow instructions in the Calibration section of this manual.