



1800

Multi-Channel Monitor

INSTRUCTIONS

Installation and Operation of the
AMC-1800 Multi-Channel Monitor

IMPORTANT:

Please read these installation and operating instructions completely and carefully before starting.

filename: 3419405E.doc

Revised March 6, 2017
Sept, 2012 Copyright ©, Feb 1999

The Armstrong Monitoring Corporation
215 Colonnade Road South, Ottawa, Ontario, Canada K2E 7K3
Tel: (613) 225-9531 • Fax: (613) 225-6965 • U.S. Toll Free: 1-800-465-5777
E-mail: gas@armstrongmonitoring.com • Internet: www.armstrongmonitoring.com



TABLE OF CONTENTS

SECTION TITLE	PAGE
1 SAFETY SYMBOLS	1
2 GENERAL INFORMATION	2
2.1 WARRANTY.....	2
2.2 LIABILITY.....	2
2.3 MODIFICATIONS AND SUBSTITUTIONS	2
2.4 PRODUCT RETURN	2
2.5 CONTACT INFORMATION.....	3
3 PRODUCT INFORMATION	4
3.1 RELAY CONTACT INFORMATION	4
4 GENERAL DESCRIPTION	5
5 INSTALLATION.....	8
5.1 LOCATION AND MOUNTING.....	8
5.2 CABLE SELECTION.....	8
5.3 WIRING OF THE MONITOR.....	8
6 OPERATION AND FEATURES.....	12
6.1 POWER-ON SELF TEST (POST).....	12
6.2 DISPLAY	12
6.2.1 DISPLAY ALL DATA MODE	12
6.2.2 DISPLAY ALARMS MODE	13
6.2.3 DISPLAY NEW ALARMS ONLY MODE	15
6.3 FEATURES.....	15
6.4 OPERATOR INTERFACE.....	19
6.4.1 OPERATOR KEYPAD	19
6.4.2 PROGRAMMING KEYPAD.....	21
6.4.3 DIP SWITCH ASSIGNMENTS.....	21
6.5 SYSTEM FAIL TRANSFER AND REMOTE RELAY CONTROL	22
6.6 AMC-1800 MENU	22
7 PREVENTIVE MAINTENANCE.....	23
7.1 GENERAL.....	23
7.2 VERIFICATION OF MONITOR	23
7.3 SENSOR/TRANSMITTER OR SENSOR MODULE MAINTENANCE	23
7.4 CALIBRATION	23



NOTE

This page intentionally left blank.

•

1 SAFETY SYMBOLS

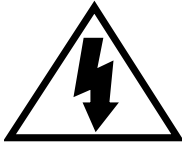

CAUTION, RISK OF DANGER. REFER TO INSTRUCTION MANUAL BEFORE OPERATIONG



CAUTION, RISK OF ELECTRIC SHOCK.

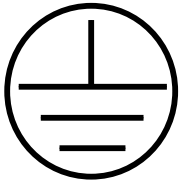

SIGNIFIES THE SYSTEM'S GROUND TERMINAL.
DC refers to direct current voltages.
VAC refers to alternating current voltages.

WARNINGS

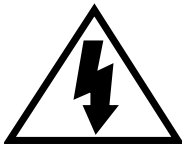

Shock Hazard - Disconnect or turn off power before servicing this instrument



WARNING – UNAUTHORIZED SUBSTITUTION OF COMPONENTS MAY IMPAIR CERTIFICATIONS AND EQUIPEMENT RATINGS



WARNING – USE OF THIS EQUIPEMENT IN ANY MANNER OTHER THAN SPECIFIED BY MANUFACTURER MAY IMPAIR OVERALL SAFETY.

Safety guidelines:

- Use a properly rated CERTIFIED AC power cable installed as per local or national codes.
- For DC powered units, DC power must be from a SELV rated source.
- A certified AC power disconnect or circuit breaker should be mounted near the controller and installed following applicable local and national codes.
- If a switch is used instead of a circuit breaker, a properly rated CERTIFIED fuse or current limiter is required to be installed as per local or national codes. Markings for positions of the switch or breaker should state (I) for on and (O) for off.
- Equipment not used as prescribed within this manual may impair overall safety.



2 GENERAL INFORMATION

2.1 WARRANTY

The AMC-1800 monitor is warranted against defects in material and workmanship for a period of two years from date of delivery. Maintenance items are not warranted. During the warranty period, *The Armstrong Monitoring Corporation* will repair or replace components that prove to be defective in the opinion of AMC. Any equipment deemed to be defective by the user should be returned to *The Armstrong Monitoring Corporation* for evaluation (see product return below). Site visits by Armstrong personnel, to evaluate/repair equipment, are not covered by this warranty. AMC is not liable for auxiliary interfaced equipment, nor consequential damage. This warranty shall not apply to any product which has been modified in any way, which has been repaired by any other party other than a qualified technician or authorized AMC representative, or when such failure is due to misuse or conditions of use.

2.2 LIABILITY

All AMC products must be installed and maintained according to instructions. Only qualified technicians should install and maintain the equipment.

AMC shall have no liability arising from auxiliary interfaced equipment, for consequential damage, or the installation and operation of this equipment. AMC shall have no liability for labour or freight costs, or any other costs or charges in excess of the amount of the invoice for the products.

THIS WARRANTY IS IN LIEU OF ALL OTHER WARRANTIES, EXPRESS OR IMPLIED, AND SPECIFICALLY THE WARRANTIES OF MERCHANTABILITY AND FITNESS FOR A PARTICULAR PURPOSE. THERE ARE NO WARRANTIES WHICH EXTEND BEYOND THE DESCRIPTION ON THE FACE THEREOF.

WARNING

CHECK TO ASSURE THE WORKING AREA IS FREE FROM HAZARDS DURING INSTALLATION OR WHEN PERFORMING MAINTENANCE, AND USE PROPER PRECAUTIONS.

2.3 MODIFICATIONS AND SUBSTITUTIONS

Due to an ongoing development program, AMC reserves the right to substitute components and change specifications at any time without incurring any obligations.

2.4 PRODUCT RETURN

All products returned for warranty or service should be shipped by prepaid freight. Please obtain a Return Material Authorization (RMA) number from AMC prior to shipping and ensure this RMA number is clearly visible on the outside of the shipping container. Material shipped without RMA will be rejected and returned. All products returned to the client will be shipped by freight collect.



2.5 CONTACT INFORMATION

For information please call 1-800-465-5777 or through contacts at www.armstrongmonitoring.com or through email directly at support@armstrongmonitoring.com.



3 PRODUCT INFORMATION

Monitor Serial Number	
Power Supply Requirements	120 VAC 60Hz 240 W
Power Supply Output	24 VDC 10A
Operating Temperature Range	-20 to 40 °C
Relative Humidity	20 to 80 %RH non condensing
I/O Cards.....	

3.1 RELAY CONTACT INFORMATION

10A DPDT Relay Ratings	Maximum Rated current	A	10
	Maximum Rated voltage	VDC/VAC	30/250
	Relay contact rating		Resistive
	Breaking capacity DC: 30 VDC	A	10

6A SPDT Relay Ratings	Maximum Rated current	A	6
	Maximum Rated voltage	VDC/VAC	24/250
	Relay contact rating		Resistive
	Breaking capacity DC: 24 VDC	A	6



4 GENERAL DESCRIPTION

The AMC-1800 Multi-Channel monitor is a micro-controller based design, providing economical advanced control, display, and annunciation capabilities for up to 24 analog current-loop (4-20mA) inputs. These inputs can consist of individual sensor channels connecting to 2 or 3 wire transmitters or alternatively, multiple sensor zones interconnected to multidrop sensor modules.

For individual sensor/transmitter channels, each system features continuous display of current information for up to 24 sensor channels including programmable labels, selectable range and engineering units. Up to three independently-adjustable alarm thresholds are provided for each 2 or 3 wire transmitter. Sensors are individually configurable to alarm on increasing levels, decreasing levels, or windowed operation (two level operation only), in addition to fail detection capabilities. Output relays are provided and easily configured to a variety of operating modes, including individual outputs for each alarm threshold and failure status for each transmitter sensor.

Inputs are continuously scanned and converted to a digital form using an analog multiplexer and analog-to-digital converter circuit. Each input channel level is regularly compared against preset alarm and fail thresholds. Sensor hysteresis and programmable alarm activation delays are provided. All sensor configuration data, including alarm thresholds and delay settings, are stored within non-volatile memory. This memory is removable to allow existing configuration data to be retained should a circuit card replacement be necessary.

In the case of inputs set up as multidrop zones, two alarm thresholds are supported and output relays would be configured for each zone. The AMC-1800 supports AMC-1228s and AMC-1222 Multidrop Sensor Modules. These modules need to be set to current mode to work with the AMC-1800 4-20mA inputs.

Additional features include an audible alarm provision for an external audible alarm and an overall system fail relay.

Output relays are provided, to a maximum configuration of four relays per sensor channel. The total maximum number of relays is either 56 SPDT 6A or 24 DPDT 10A relays with the enclosure provided. These relays may be programmed to indicate individual alarm outputs for each threshold as well as failure, or may be programmed to provide combined alarm outputs or combined sensor modes for installations where cost reduction through a reduced relay count is required. A programmable minimum run timer and activation delay is available for each relay.

To provide maximum flexibility and economy, sensor inputs and output relay connections are made to Input/Output (I/O) cards, each card providing for a maximum of 8 inputs and 32 relays. Up to 3 such cards may be provided, for a total of 24 inputs. This flexibility is restricted for relays by the maximum number stated previously.

Indication of sensor and alarm status is provided using a vacuum-fluorescent (VFD) display. Review and modification of system configuration is performed using this display in conjunction with **Programming Keypad Pushbuttons** located inside the system enclosure. **Operator Keypad Pushbuttons** are also provided for accessing operational functions.

An internal power supply provides power for the control electronics, gas sensors and alarm relay coils.

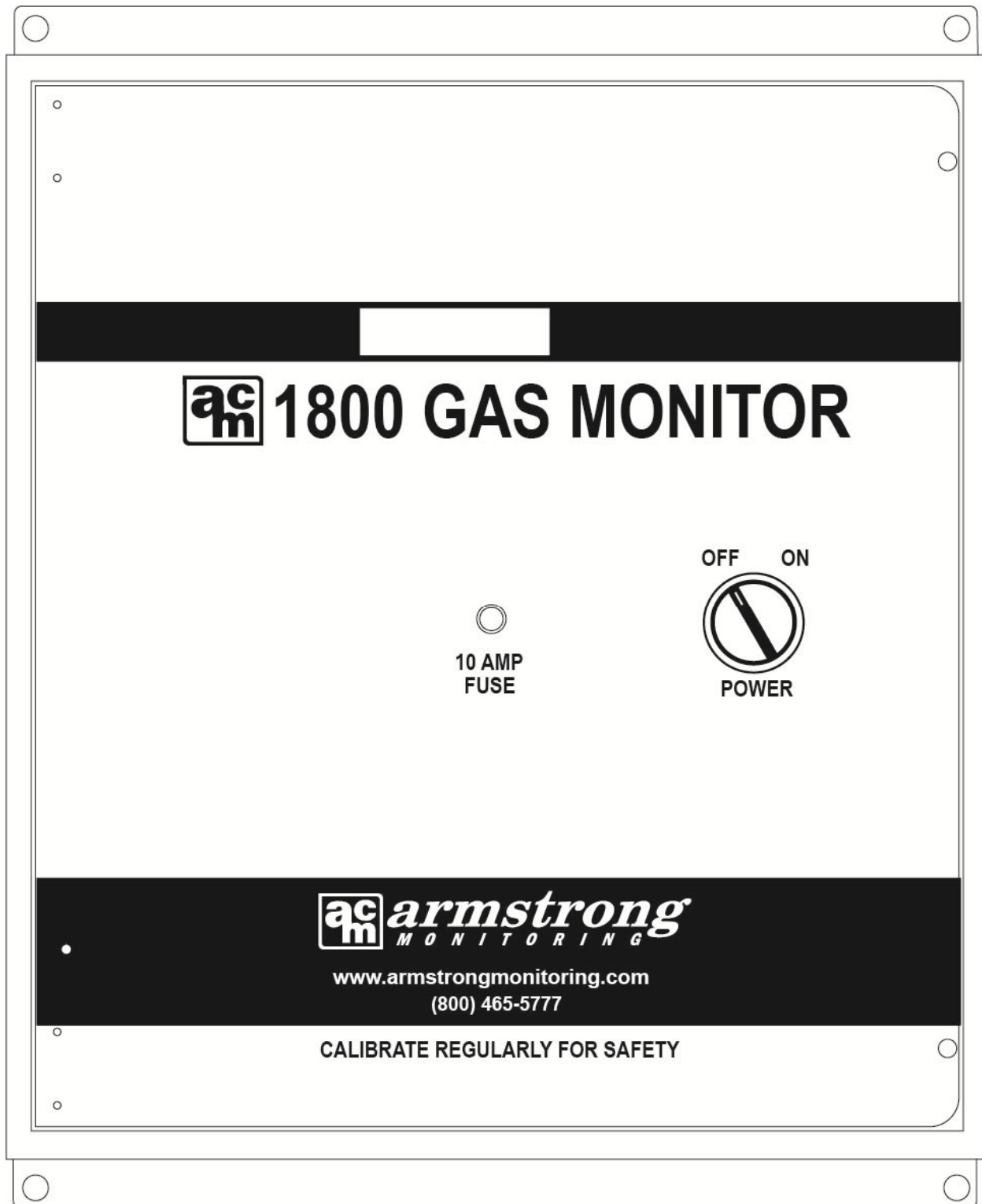

FIGURE 1: Front Panel Layout.

Power Switch: - Main AC power switch for all channels.

Fuse Holder: - Front panel mounted for easy access to the fuse.

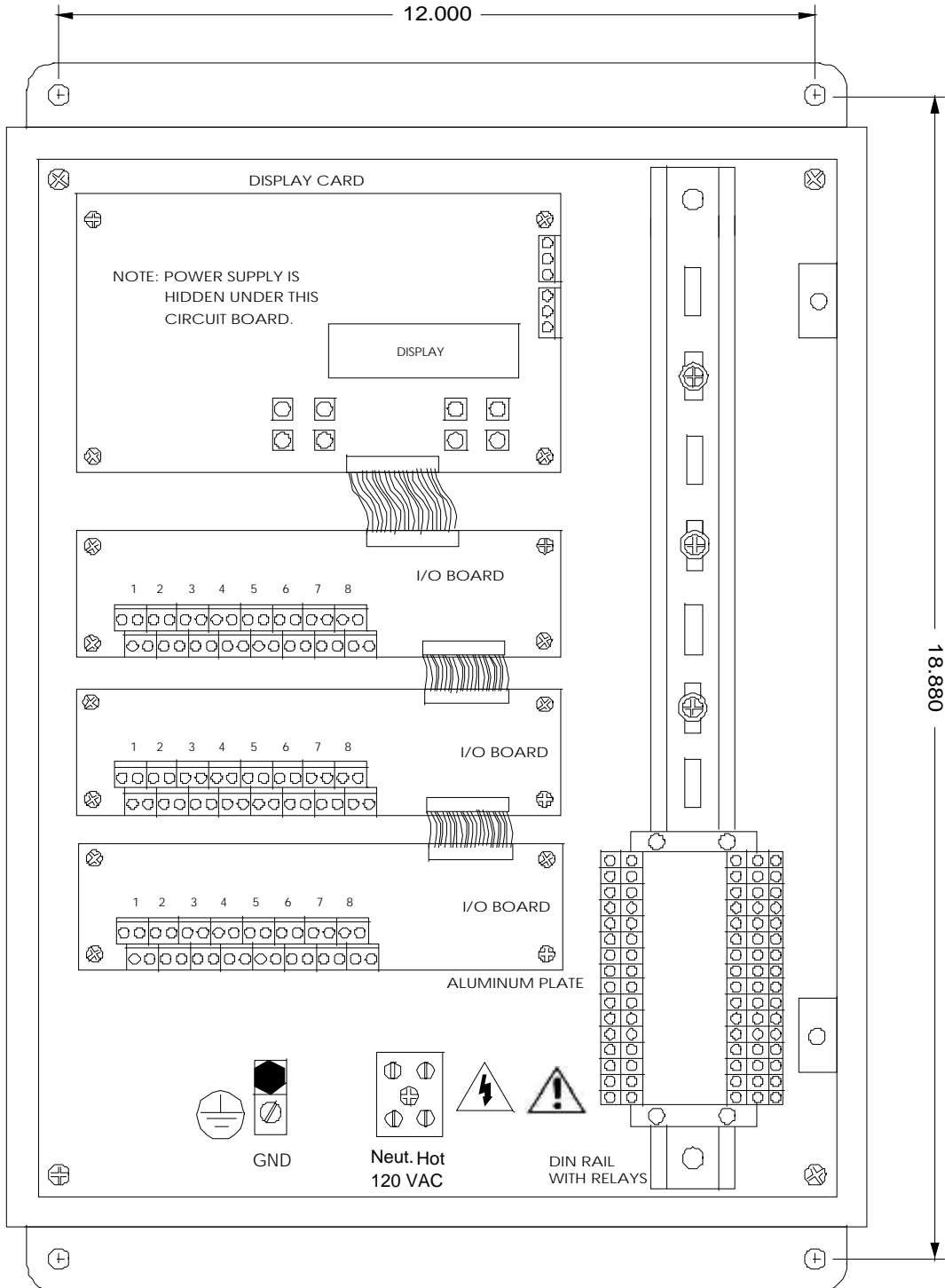

FIGURE 2: Internal Layout Of Components.



5 INSTALLATION

5.1 LOCATION AND MOUNTING

Care should be taken to securely fasten the AMC-1800 monitor unit on a solid, non-vibrating surface or structure at eye level. Mount the monitor in a NON-HAZARDOUS area where the unit can be observed periodically. (See Figure 2 for mounting hole locations.)

NOTE: All cable entry MUST be through the BOTTOM of the monitor enclosure only. Other entry locations will allow foreign materials to enter the enclosure, possibly causing damage to internal components. Mounting hardware and conduit connections are NOT supplied.

5.2 CABLE SELECTION

Connections from monitor to sensor/transmitter should be made using shielded, 2 or 3 conductor cable (depending on type of transmitter used). The multidrop sensor modules require shielded 3 conductor cable. For best signal transmission and maximum noise rejection, run cable through steel conduit (cable shield must be grounded at the monitor). The monitor's internal power supply provides 24VDC to power the transmitters. For basic selection of cable size and length (between monitor and sensor), refer to the cable selection chart in the appropriate transmitter or multidrop sensor module manual(s).

5.3 WIRING OF THE MONITOR

Power Supply: The monitor operates on 120 VAC, 60 Hz. An internal power supply runs the internal circuitry at low voltages. The power supply connections are made at the power terminal block located inside the monitor.

Relays: The I/O circuit card can drive up to 32 relays which operate as programmed with alarms. For relay contact arrangement, see Figure 3 for the 6A 250V SPDT relays and Figure 4 for the 10A 250V DPDT relays. The relay contacts are available for activating a remote alarm and/or, blower motors where moving parts are fully guarded, pumps or lighting circuits. Relays are rated as per section 3.1.

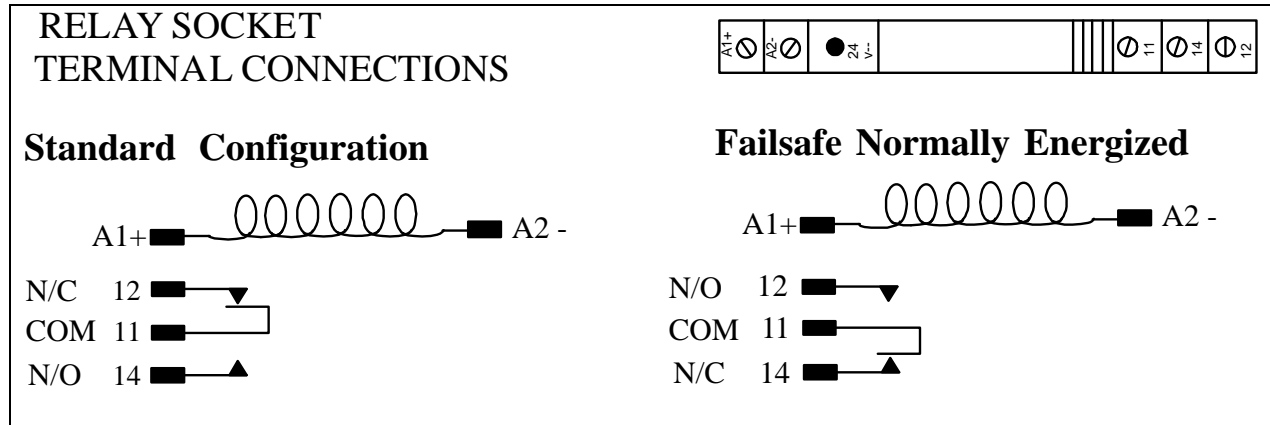
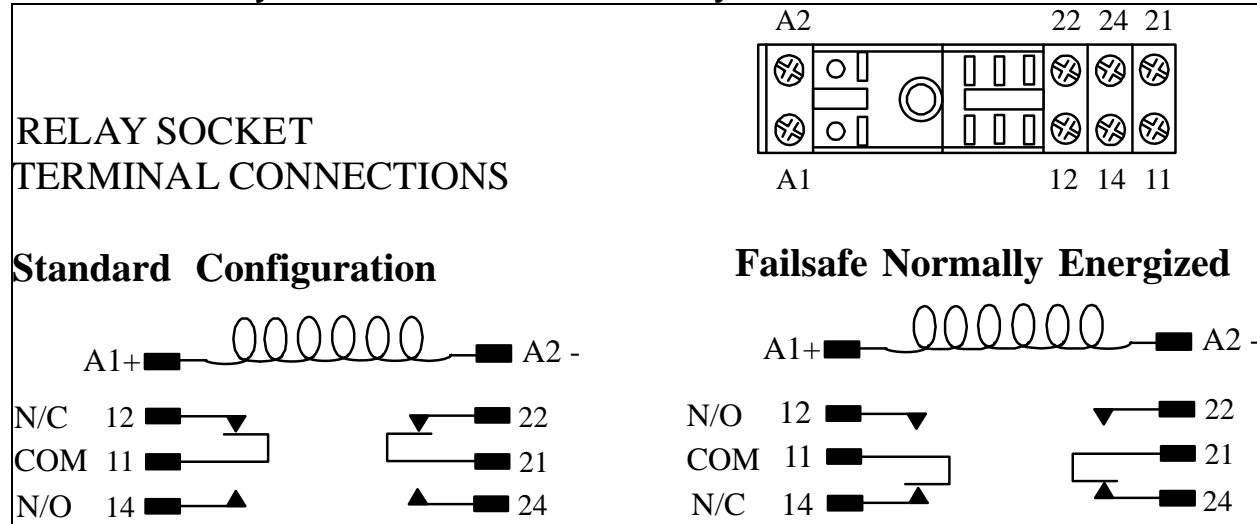
FIGURE 3: Relay Terminals For 6A SPDT Relay

FIGURE 4: Relay Terminals For 10A DPDT Relay
Inputs:

Each sensor connects to a set of sensor terminals (-,S,+) on the main terminal block located on the I/O card. Wiring detail for 2 and 3 wire types shown in Figure 5A. For multidrop sensor module see Fig 5B. See specific sensor/transmitter or multidrop sensor module manual.

Analog Output:

A 4-20 mA analog output is provided from each channel with a 4-20 mA sensor input. This output tracks the input signal to allow connection for an external recording or monitoring device. Since analog “-” is common between channels, either a differential or single ended interconnected device can be used. Maximum load for this signal is 250 Ohms. See Figure 5A for connections. Note these outputs are not used when multidrop inputs are used.

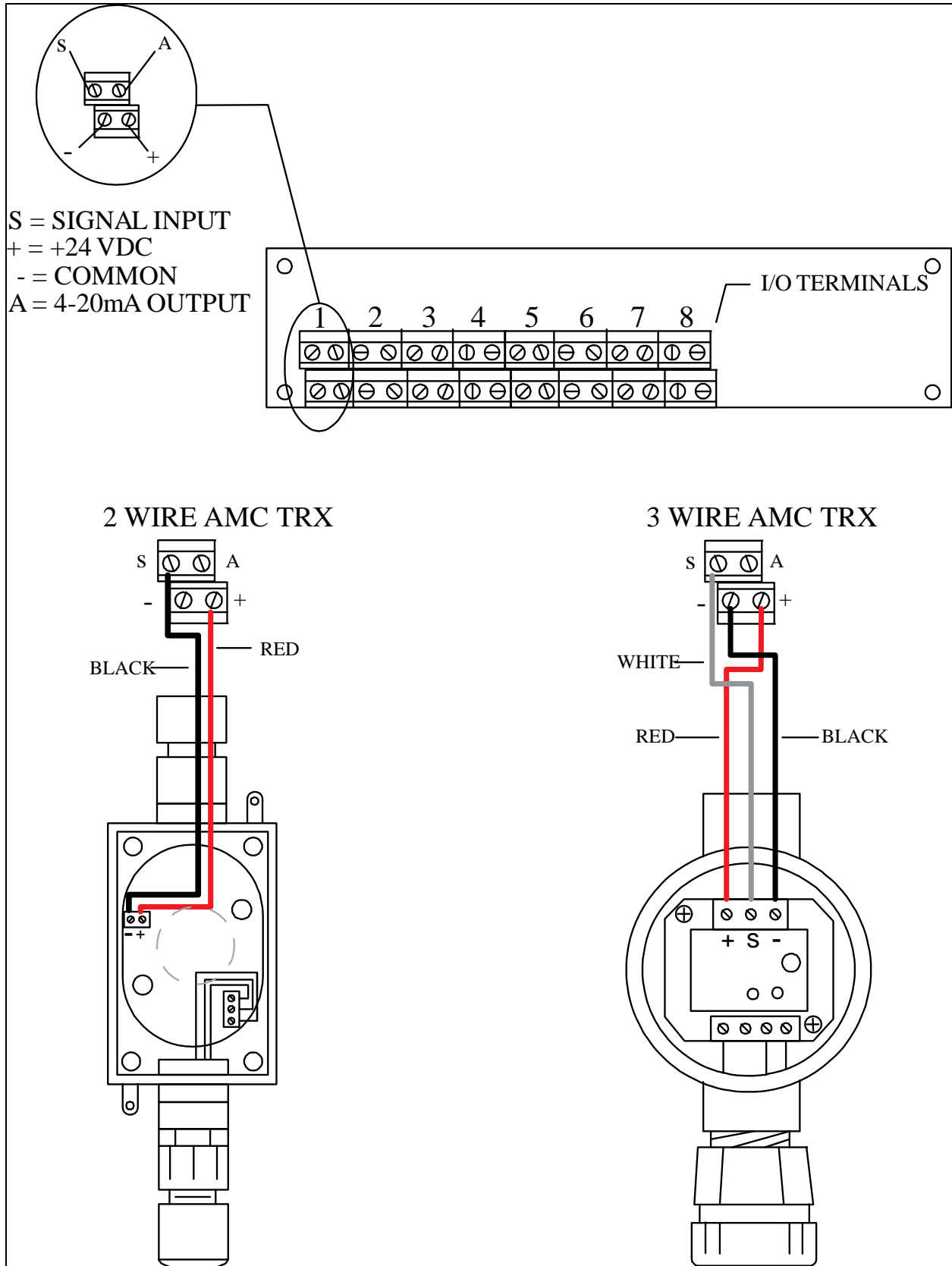
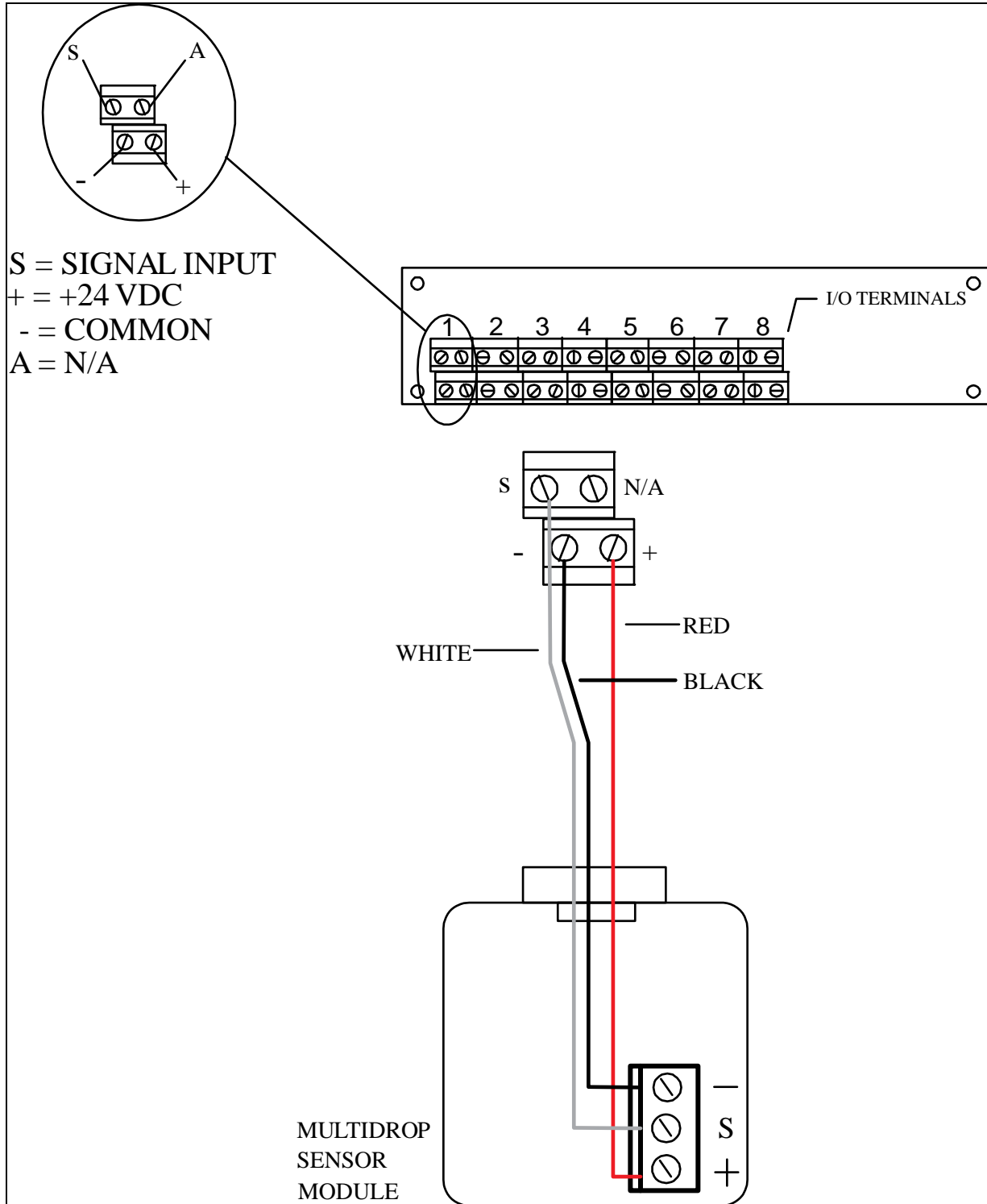

FIGURE 5A: Sensor/Transmitter Terminal Block Connections.

**FIGURE 5B: Multidrop Sensor Module Terminal Block Connections**

6 OPERATION AND FEATURES

6.1 POWER-ON SELF TEST (POST)

The micro-controller provides read/write power-up testing of all RAM memory, checksum verification of the program code, and database integrity checking of the stored configuration data. Detected failures cause the common fail relay to remain de-energized, the audio alarm to remain active, and an error message on the operator display.

On power-up, after the initial POST has been completed, the display shall present a title page identifying the product, manufacturer and software revision. After approximately three seconds, assuming that no errors were encountered, the display shall immediately enter the programmed display mode. (See Figure 6)



FIGURE 6: Power-On Display

The program then executes a continuous loop, in which each defined sensor input is sequentially scanned, alarm thresholds determined, pushbuttons scanned, outputs set as required, and the display updated.

6.2 DISPLAY

Display of gas concentrations, alarm, and failure conditions is provided using a VFD display. This display is mounted behind the front panel of the enclosure, and is visible through a transparent window. This arrangement provides physical protection for the display, while allowing the display to be viewed when the front panel is opened for setup or maintenance. The display may be programmed to operate in one of these modes:

Display All Data Mode

Display Alarms Mode

Display New Alarms Only Mode

6.2.1 DISPLAY ALL DATA MODE

The display will continuously cycle through all defined sensors, showing the sensor number, gas label, current concentration (engineering units or bar graph display) and any alarm conditions active for each input. (See Figure 7A/B)

6.2.3 DISPLAY NEW ALARMS ONLY MODE

Only unacknowledged alarms will be displayed. (See Figure 9A/B)

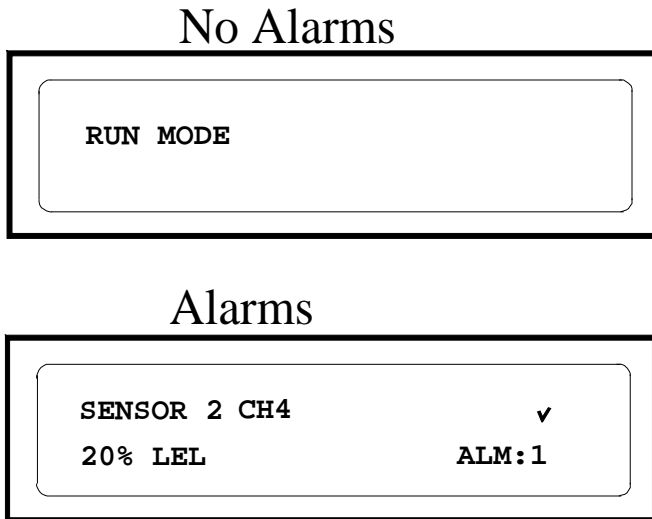

FIGURE 9A: Display New Alarms Only Mode with 4-20mA Transmitters

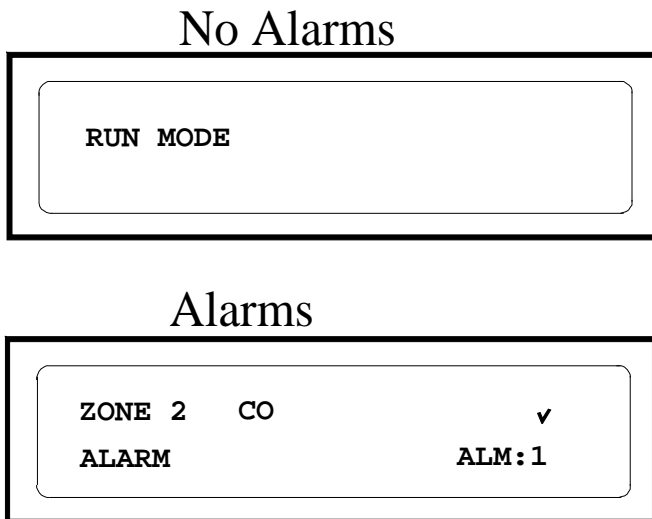

FIGURE 9B: Display New Alarms Only Mode with Multidrops

6.3 FEATURES

Inputs:

Analog 4-20mA sensor/transmitters are supported, where 4 mA represents a gas concentration of zero and 20 mA represents a programmable full scale concentration. Either 2 or 3 wire transmitter types can be connected. Multidrop sensor modules are supported where 4mA represents no Alarm, 8 mA represents a low alarm and 12mA represents a high alarm. Eight Inputs are provided for each I/O cards providing a maximum of 24 inputs with 3 I/O cards. Inputs are identified on display and AMC Manager as Sensor 1, 2, 3, and



continued up to 24.

- Gas Label:** A gas label may be selected for each input, chosen from a pre-programmed list of gas types or 9 user configurable labels. For ease of configuration, selection of a gas label automatically sets various associated input parameters to a default value. For multidrop zones where both CO multidrop sensor modules and NO₂ multidrop sensor modules are used a user configurable label is required.
- Displayed units:** Engineering units for display of gas concentration may be selected individually for each sensor/transmitter. Available selections are: PPM (parts per million), PPB (parts per billion), %LEL and %VOL. Multidrop sensor modules use EXT-I.
- Full scale (span):** The full scale sensor level (input of 20 mA) may be individually programmed for each sensor/transmitter, in step sizes appropriate to the displayed units. For example a typical CO sensor has a range of 0-100PPM so the full scale sensor level is 100 PPM. For multidrop sensor modules an attached configuration sheet displays the PPM value for the low and high alarm conditions.
- Zero buffering:** To reduce false readings based on external noise and zero level sensor drift, a zero buffering feature is provided. A system wide value within the range of 0 to 5% of full scale may be set in 0.1% increments. Any sensor value within this range will be interpreted and displayed as zero level. This feature may be quickly disabled using a DIP switch during sensor calibration checks. This feature does not apply to multidrop sensor modules.
- Alarm detection:** Alarm detection for each input dedicated to a sensor /transmitter may be individually programmed to operate in one of four modes: alarms disabled, alarm thresholds on increasing concentration, alarm thresholds on decreasing concentration, and windowed alarm (high/low) operation. For the multidrop sensor modules that support CO and NO₂ only alarms disabled and increasing concentration apply.
- Up to three alarm thresholds may be configured for each sensor/transmitter input (two thresholds for windowed operation). Each alarm threshold is individually adjustable in increments of % full scale.
- Maximum time to scan a full complement of inputs, determine alarms and fail conditions, and annunciate such conditions using the relay outputs shall not exceed two seconds.
- An adjustable hysteresis value is applied to alarm detection for sensor transmitters. This hysteresis is provided to prevent multiple alarms and relay oscillation should a sensor level remain near the threshold setting. The hysteresis level is adjustable from 0 to 5% of full scale in 0.1% increments at the system level for all sensors simultaneously.

Sensor failure detection: Failure detection for each sensor/transmitter is provided. The failure threshold for each input may be individually programmed within 0.2 – 2.0 mA, in steps of 0.1 mA. Failure detection may also be disabled for individual sensor channels. For setup convenience, a default fail threshold may be globally set. No hysteresis is provided on failure detection. Unit will display as shown in Figure 10. For multidrop sensor modules the threshold should be set to 2mA.

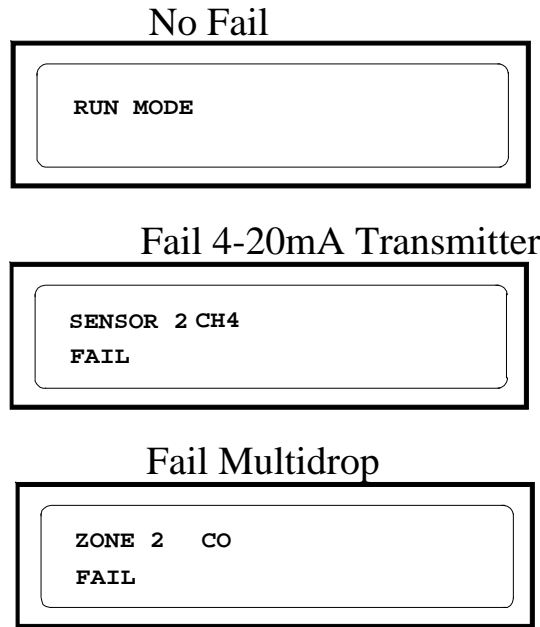

FIGURE 10: Failure Detection

The failure condition for each input may be assigned to any relay output, and may also be combined with alarm outputs. In addition, any input in a failed state will cause the common fail relay output to become de-energized. Failure detection is disabled for undefined inputs.

Alarm activation delay: An individually adjustable alarm activation delay is available for each alarm threshold for each sensor (excluding sensor failure alarms), in increments of 1 minute, up to a maximum of 60 minutes. In addition, a common, adjustable power-up delay, programmable from 0 to 999 seconds, is provided on all alarm and failure indications.

Output relays: External indication of alarms is made available through the use of output relays. Each relay may be assigned to energize or de-energize on detection of one or more alarms and/or fail conditions. Additionally, a count value may be programmed, such that a minimum number of alarm conditions must be present before the relay is energized (voting logic).

Several types of relays may be provided, depending on the application. The standard relay type is a slim single-pole, Form C



relay (SPDT), capable of switching up to 6A at 250VAC. Another option is a larger Double pole double throw (DPDT) relay capable of switching up to 10A at 250VAC. Relay drivers (coil drive circuitry) are provided in increments of 32, corresponding to each I/O card (which also provides 8 sensor inputs), in this way, up to 32 relays can exist per I/O card. Relay numbering starts at 1, corresponding to the first relay within the first group on the first I/O Card connected to the Display Card. An LED exists only for the slim 6A SPDT relay indicating when the coil is energized. The maximum number of relays per enclosure is 56 for the 6A SPDT relays and 24 for the 10A DPDT relays.

Minimum run time: An individually adjustable minimum run (activation) time is available for each relay output, in increments of 1 minute, up to a maximum of 60 minutes.

Latching relay operation: Each relay may be programmed to reset automatically after the corresponding alarm condition has been cleared (and the minimum run timer has expired, if enabled), or to be maintained in the alarm state until manually reset.

Audible alarm: An internal audible alarm is provided. An output for activation of a remote audible alarm and/or relay is also provided. This alarm/relay may be programmed to energize on all detected alarms and failures, alarms only, or high alarms only (including outside of the preset window for windowed alarms). The audible alarm may also be disabled by means of a DIP-switch. Alarm activation is affected by any programmed alarm activation delays, but not by relay minimum run time.

System fail relay: A normally-energized fail relay output is provided, which will become de-energized on power failure, microcontroller failure, or failure of any defined input. This output is not subject to alarm activation delays or minimum run times. A power or controller failure will result in de-energizing of this fail relay output. An intermittent (power) failure resulting in a system reset will result in a momentary failure indication. This relay will be held in the non-failed state during the subsequent power-up delay. This relay will be held in the failed state while CAL Mode is selected.

6.4 OPERATOR INTERFACE

Keypads: The display card contains a pair of four button keypads. One is the Operator Keypad which provides function keys or test, reset, hold and acknowledge. (See Figure 11)

The other is a Programming Keypad which provides a security protected interface for reviewing and modifying program parameters.

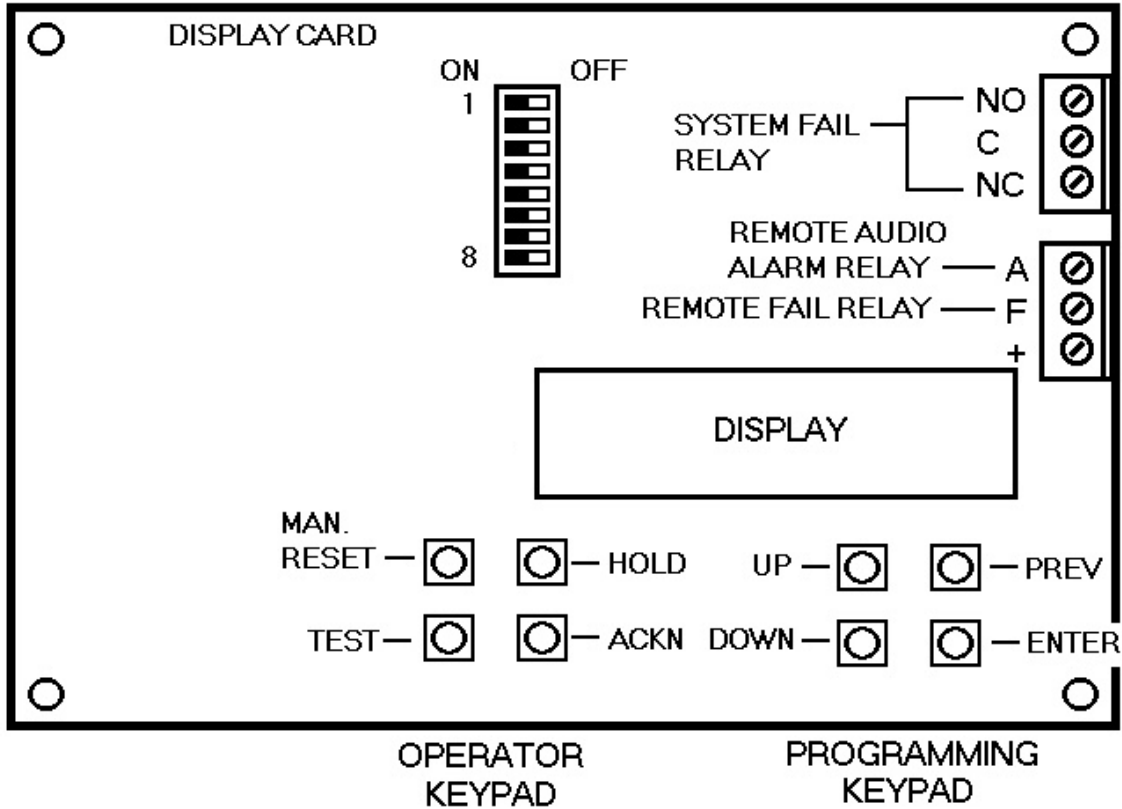

FIGURE 11: Operator Interface

6.4.1 OPERATOR KEYPAD

ACKNOWLEDGE Pushbutton: When pressed, this pushbutton shall silence the audible alarm indication resulting from all active alarms for an individual, adjustable, preset length of time within the range of 0 to 60 minutes or infinite. Setting is value to "0" shall disable the acknowledge feature.

It is possible to configure this pushbutton to also reset all associated relay output indications, subject to defined minimum run times for each relay.



In this way, an additional or recurring sensor alarm condition shall again cause an alarm/fail indication.

Pressing the acknowledge pushbutton in response to new or recurring alarm conditions shall reset the acknowledge timer to the preset time, including conditions previously acknowledged.

Failure indications cannot be acknowledged, except to reset the system fail relay.

TEST Pushbutton:

A test pushbutton is provided, which, while pressed, shall cause continuous activation of all relay outputs (energized or de-energized, depending on configuration), activation of the system fail relay output (to the de-energized state), and continuous activation of the audio alarm (if enabled). Input processing and updating of internal status and timers shall continue. When released, all outputs shall return to normal operation.

HOLD Pushbutton:

A hold pushbutton is provided, which, while pressed during normal operation, shall freeze the display on the currently displayed input until released. Upon release, the display shall immediately advance to the next input (depending on the display mode selected), allowing the HOLD pushbutton to be used to quickly step through multiple inputs.

RESET Pushbutton:

When pressed, this resets any latching relays, providing the alarm condition has subsided.

6.4.2 PROGRAMMING KEYPAD

System setup, configuration and maintenance is performed using the VFD display and the programming keypad. Four pushbuttons are provided, labeled **PREV**, **UP**, **DOWN** and **ENTER**. These pushbuttons easily allow all setup menus to be traversed, parameters selected and value entered, as follows:

PREVIOUS Pushbutton: Moves to the next highest menu level, or exits setup mode from the top level of the setup menu.

UP, DOWN Pushbutton: Scrolls through the current menus, selects parameters, increments or decrements selected parameter option or value.

ENTER Pushbutton: Selects a sub-menu or confirms a menu (parameter) choice.

All systems parameters except selection of default Display Mode, require a password-protected log-in before they can be modified. Entry into “System Setup” mode shall be implemented by pressing the ENTER pushbutton while in any “Display” mode.

Immediately upon entry into “System Setup” mode, the user shall be required to enter a 4-digit alphanumeric password before and system parameters modified (except for the selected display mode). The password characters shall be selected using the UP, DOWN and ENTER keys, and each digit of the password shall be blanked while the following digits are being entered. The default password is 1234.

Until a correct password is used to log into the system, setup data may be viewed but not changed. The user password shall be changeable only after the user has logged-in.

6.4.3 DIP SWITCH ASSIGNMENTS

The Display Card DIP switches are used to select various system setup and test features. The DIP switch assignments are tabled below. See Fig. 12

Switch	Function	Normal Position	Description
1	Audio Disable	ON	OFF to disable audio alarm
2	Delay Disable	ON	OFF to disable all relay activation delays
3	Zero Buff Disable	ON	OFF to disable zero buffering
4	Min Run Disable	ON	OFF to disable all relay minimum run times
5	CAL Mode	OFF	ON to activate CAL mode
6			Not used
7, 8	Language Select	See Description	7 OFF, 8 OFF = ENGLISH 7 ON, 8 OFF = FRENCH 7 OFF, 8 ON = SPANISH (future) 7 ON, 8 OFF = GERMAN (future)

FIGURE 12: DIP Switch Assignments

6.5 SYSTEM FAIL TRANSFER AND REMOTE RELAY CONTROL

The System Fail transfer relay has connections via TB1 as shown in Fig 11. The relay connections shown on the card silkscreen reflect the signal state with the AMC-1800 Display card in an unpowered state.

The Remote relay control is via TB3. The signals are shown in the TB3 silkscreen. The + signal is the 24VDC rail, the F signal is the external relay drive, and the A signal is the external Audio drive.

6.6 AMC-1800 MENU

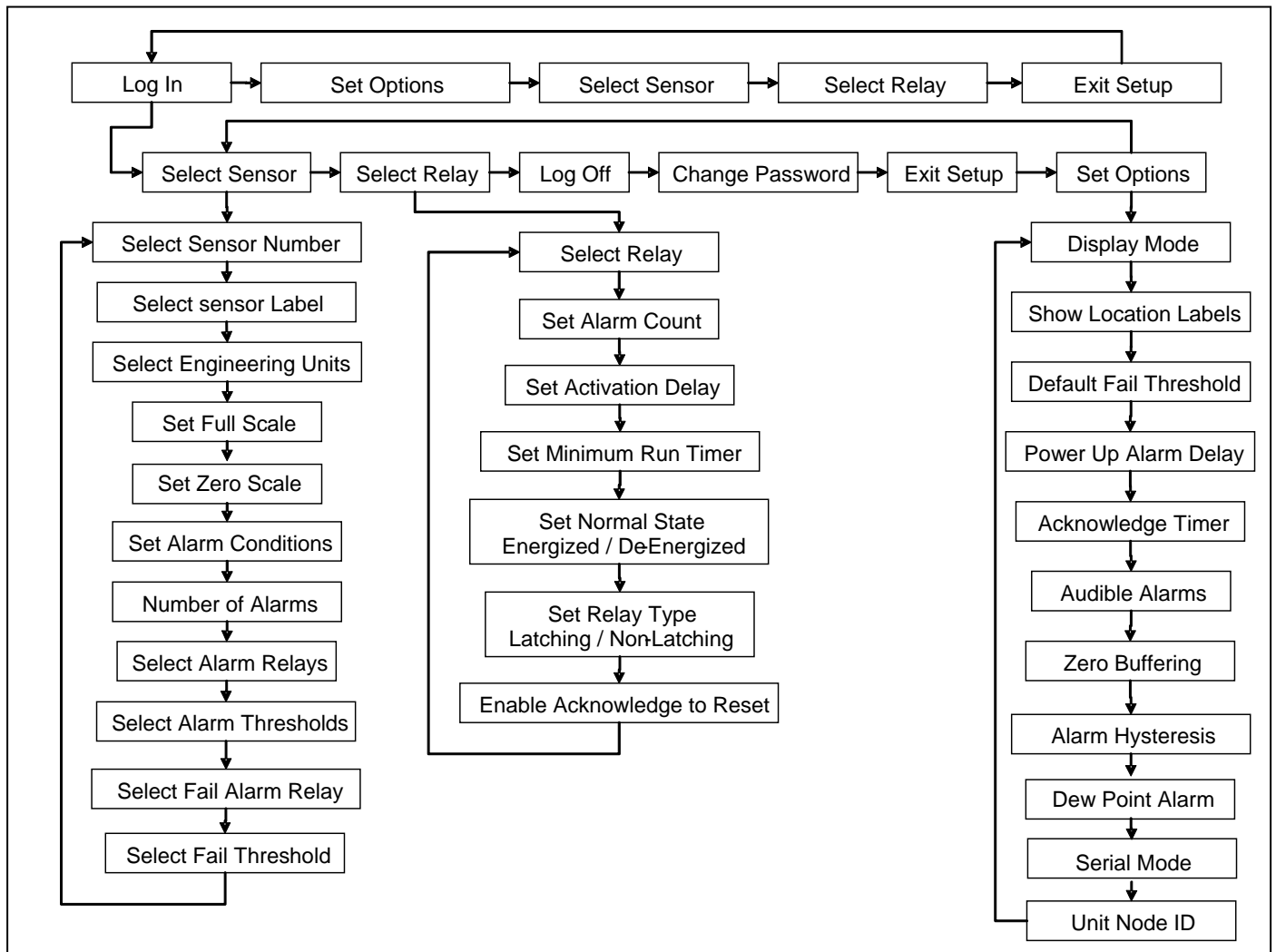

FIGURE 13: AMC-1800 Menu



7 PREVENTIVE MAINTENANCE

7.1 GENERAL

The monitor unit should be brushed or wiped clean once a year or more, of any dust or dirt which settles on it, depending on the accumulation.

The unit SHOULD NOT be submerged in water or other liquids. Also hosing and other conditions that could cause a liquid to enter the enclosure should be avoided.

7.2 VERIFICATION OF MONITOR

Verification of operation should be done at least once every 6 months. For highly demanding applications more frequent verification is recommended.

7.3 SENSOR/TRANSMITTER OR SENSOR MODULE MAINTENANCE

For a sensor/transmitter or sensor module, follow the recommended procedures described in the appropriate sensor/transmitter or multidrop sensor module manual.

7.4 CALIBRATION

Calibration is recommended two times per year.